

ET1700 Series

7-Day Electronic Time Switch

The ET1700 Series 7-Day Electronic Time Switches feature independent 7-day programming to provide flexibility for applications where load switching differs each day of the week. These time switches provide dependable and uncomplicated performance, plus to-the-minute programming for accurate load control and reduced energy costs. Up to 28 setpoints or events can be preset to automatically repeat. The program can be disabled at any time by placing the time switch in the Manual operating mode. Control buttons provide manual control of each circuit independently regardless of the operating mode. All models contain industrial-grade AAA alkaline batteries to provide time keeping and automatic carryover for a minimum of three years. The batteries are easily replaceable and do not require removing the time switch mechanism or field wiring. Each time switch is housed in a lockable enclosure to protect against vandalism and unauthorized tampering.

Features

- Program can be repeated on a weekly basis
- Multi-volt operation from 120-277 VAC, 50/60 Hz
- To-the-minute programming for accurate load control and reduced energy costs
- Up to 28 setpoints
- Automatic Daylight Saving Time (DST) ON/OFF adjustment (factory enabled)
- Non-volatile EEPROM memory protects programming indefinitely
- Temporary override or permanent manual override available via control buttons
- 2-circuit models are field (jumper) configurable for:
2 independent outputs, DPST output,
or 1 channel ON pulse/OFF pulse output

Ratings

Enclosure Options:	Standard: Type 1 Gray Painted Steel R-Option: Type 3R Gray Painted Steel PD82 Option: Type 3R Gray High-Impact UV Resistant Polycarbonate Plastic with Clear Cover
Knockouts:	Combination 1/2" & 3/4" knockouts Bottom: 2, Left: 1, Right: 1, Back: 1
Frequency:	120, 208, 240, 277 VAC 50/60 Hz
Operating Temperature:	-40°F to 155°F (-40°C to 68°C)

ET1705, ET1725 Models

N.O. Contact Ratings:	Resistive: 30 Amps @ 120/240 VAC Resistive: 20 Amps @ 28 VDC Inductive: 30 Amps @ 120/240 VAC Tungsten: 5 Amps @ 120/240 VAC Ballast: 20 Amps @ 120-277 VAC Motor: 1 HP @ 120 VAC Motor: 2 HP @ 240 VAC
-----------------------	---

Project: _____

Location: _____

Product Type: _____

Contact/Phone: _____

Model #: _____



ET1715 Models

N.O./N.C. Contact Ratings:

Resistive: 20 Amps (N.O.), 10 Amps (N.C.) @ 120/240 VAC
 Inductive: 20 Amps (N.O.), 10 Amps (N.C.) @ 120/240 VAC
 Tungsten: 5 Amps (N.O.) @ 120/240 VAC
 Ballast: 20 Amps (N.O.), 3 Amps (N.C.) @ 120-277 VAC
 Motor: 1 HP (N.O.), ¼ HP (N.C.) @ 120 VAC
 Motor: 2 HP (N.O.), ½ HP (N.C.) @ 240 VAC

Pulse Feature:

2-circuit models feature 2-second pulse option for contactor and bell ringing applications

Auto DST:

Automatic adjustment for Daylight Saving Time

Battery Backup:

Two field-replaceable AAA batteries maintain date and accurate time for a minimum of 3 years. Batteries can be replaced when power to mechanism is activated.

Wiring Terminals:

#18 to #10 AWG wire

Minimum ON/OFF Time:

1 minute

Maximum ON/OFF Time:

6 days, 23 hours 59 minutes

Warranty:

Limited 1 year

Model Number	Circuits	Switch	Volts AC	Rating	Enclosure	Shipping Weight
ET1705C	1	SPST	120, 208, 240, 277	30 Amps	Type 1 Steel	2.9 lbs (1.3kg)
ET1705CPD82	1	SPST	120, 208, 240, 277	30 Amps	Type 3R Plastic	3.6 lbs (1.6kg)
ET1705CR	1	SPST	120, 208, 240, 277	30 Amps	Type 3R Steel	3.6 lbs (1.6kg)
ET1715C	1	SPDT	120, 208, 240, 277	20/10 Amps	Type 1 Steel	2.9 lbs (1.3kg)
ET1715CPD82	1	SPDT	120, 208, 240, 277	20/10 Amps	Type 3R Plastic	3.6 lbs (1.6kg)
ET1715CR	1	SPDT	120, 208, 240, 277	20/10 Amps	Type 3R Steel	3.6 lbs (1.6kg)
ET1725C*	2	SPST	120, 208, 240, 277	30 Amps	Type 1 Steel	2.9 lbs (1.3kg)
ET1725CPD82*	2	SPST	120, 208, 240, 277	30 Amps	Type 3R Plastic	3.6 lbs (1.6kg)
ET1725CR*	2	SPST	120, 208, 240, 277	30 Amps	Type 3R Steel	3.6 lbs (1.6kg)

*Can be wired as DPST

Specification

The time switch shall be of the 7-day electronic type, capable of permitting up to 28 setpoints or events weekly. The time switch shall provide a minimum ON or OFF time of 1 minute. Time switch to be powered by ___ (120)(208)(240)(277) VAC, ___ (50)(60) Hz power supply. The time switch mechanism shall be a snap-in design to provide easy mechanism removal for mounting the enclosure. The time switch enclosure shall be a _____(Type 1 Steel)(Type 3R Steel)(Type 3R Plastic) lockable enclosure that shall be painted with an electrostatic process to eliminate the potential for corrosion. The time switch shall provide clear terminal identification on a non-curling terminal insulator. A visual indicator shall be provided in the time switch for indicating output load status. Terminal connections shall be made using teeter-type terminal screws to provide secure connections for wire sizes up to #10 AWG. Switch configuration shall be _____ (SPST)(DPST) (SPDT) with a UL or CSA listed switch rating of:

(If SPST:)

- Resistive: 30 Amps @ 120/240 VAC
- Resistive: 20 Amps @ 28 VDC
- Inductive: 30 Amps @ 120/240 VAC
- Tungsten: 5 Amps @ 120/240 VAC
- Ballast: 20 Amps @ 120-277 VAC
- Motor: 1 HP @ 120 VAC
- Motor: 2 HP @ 240 VAC

(If SPDT:)

- Resistive: 20 Amps (N.O.), 10 Amps (N.C.) @ 120/240 VAC
- Inductive: 20 Amps (N.O.), 10 Amps (N.C.) @ 120/240 VAC
- Tungsten: 5 Amps (N.O.) @ 120/240 VAC
- Ballast: 20 Amps (N.O.), 3 Amps (N.C.) @ 120-277 VAC
- Motor: 1 HP (N.O.), ¼ HP (N.C.) @ 120 VAC
- Motor: 2 HP (N.O.), ½ HP (N.C.) @ 240 VAC

The time switch shall be UL or CSA listed under UL category 916 Energy Management Equipment and shall be Intermatic model _____(See Model Numbers Listed).

Diagrams

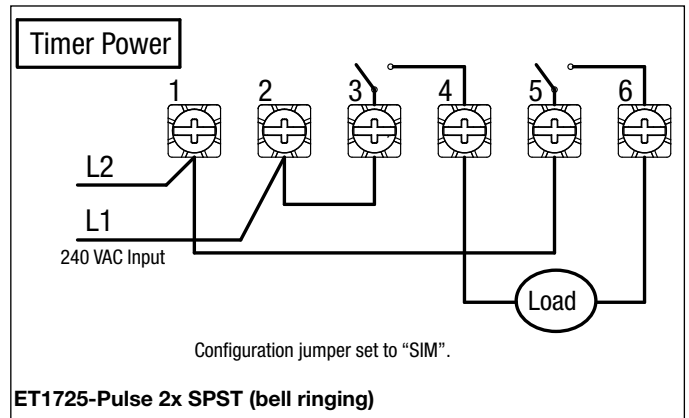
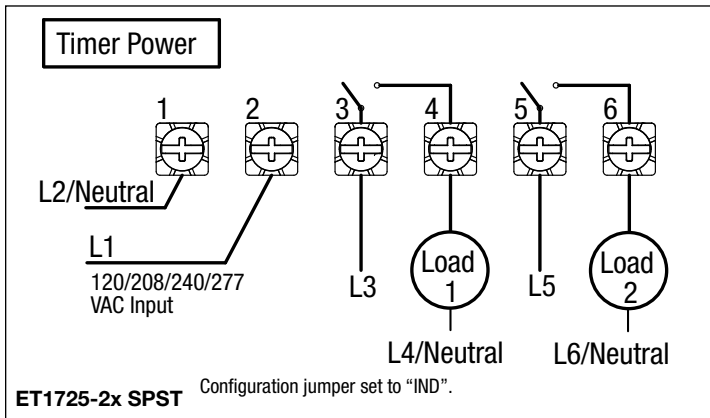
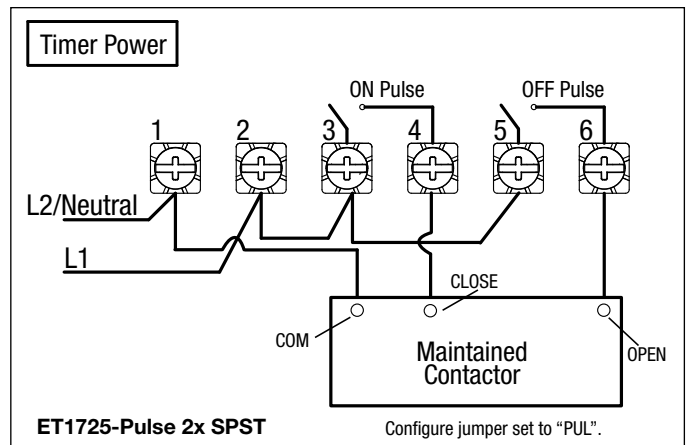
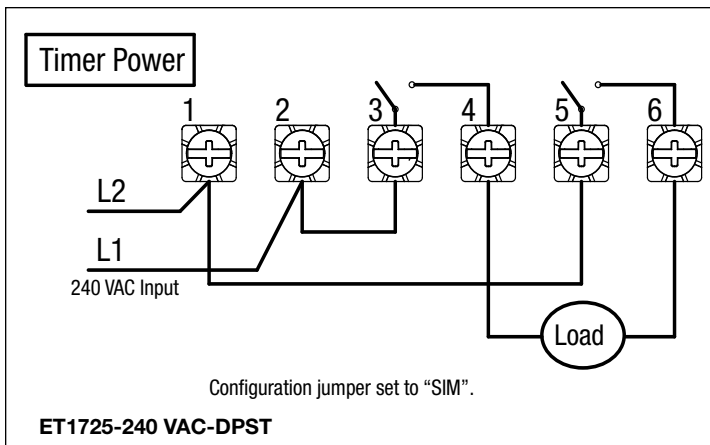
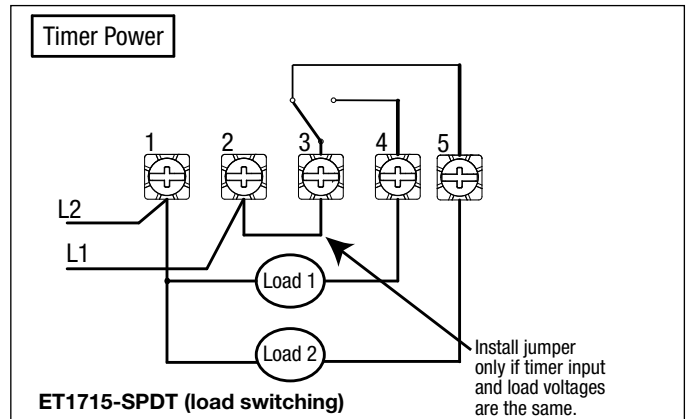
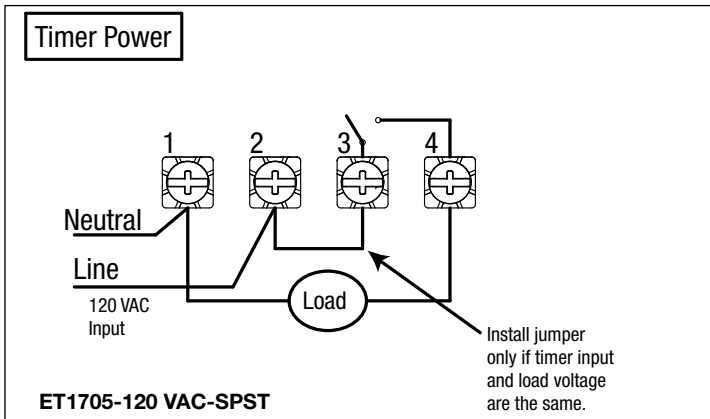

ET1700 Series

7-Day Electronic Time Switch

The ET1700 Series 7-Day Electronic Time Switches feature independent 7-day programming to provide flexibility for applications where load switching differs each day of the week. These time switches provide dependable and uncomplicated performance, plus to-the-minute programming for accurate load control and reduced energy costs. Up to 28 setpoints or events can be preset to automatically repeat. The program can be disabled at any time by placing the time switch in the Manual operating mode. Control buttons provide manual control of each circuit independently regardless of the operating mode. All models contain industrial-grade AAA alkaline batteries to provide time keeping and automatic carryover for a minimum of three years. The batteries are easily replaceable and do not require removing the time switch mechanism or field wiring. Each time switch is housed in a lockable enclosure to protect against vandalism and unauthorized tampering.

Features

- Program can be repeated on a weekly basis
- Multi-volt operation from 120-277 VAC, 50/60 Hz
- To-the-minute programming for accurate load control and reduced energy costs
- Up to 28 setpoints
- Automatic Daylight Saving Time (DST) ON/OFF adjustment (factory enabled)
- Non-volatile EEPROM memory protects programming indefinitely
- Temporary override or permanent manual override available via control buttons
- 2-circuit models are field (jumper) configurable for:
2 independent outputs, DPST output,
or 1 channel ON pulse/OFF pulse output

Ratings

Enclosure Options:	Standard: Type 1 Gray Painted Steel R-Option: Type 3R Gray Painted Steel PD82 Option: Type 3R Gray High-Impact UV Resistant Polycarbonate Plastic with Clear Cover
Knockouts:	Combination 1/2" & 3/4" knockouts Bottom: 2, Left: 1, Right: 1, Back: 1
Frequency:	120, 208, 240, 277 VAC 50/60 Hz
Operating Temperature:	-40°F to 155°F (-40°C to 68°C)

ET1705, ET1725 Models

N.O. Contact Ratings:	Resistive: 30 Amps @ 120/240 VAC Resistive: 20 Amps @ 28 VDC Inductive: 30 Amps @ 120/240 VAC Tungsten: 5 Amps @ 120/240 VAC Ballast: 20 Amps @ 120-277 VAC Motor: 1 HP @ 120 VAC Motor: 2 HP @ 240 VAC
-----------------------	---

Project: _____

Location: _____

Product Type: _____

Contact/Phone: _____

Model #: _____



ET1705C



ET7115CPD82



ET1725CR

ET1715 Models

N.O./N.C. Contact Ratings:

Resistive: 20 Amps (N.O.), 10 Amps (N.C.) @ 120/240 VAC
 Inductive: 20 Amps (N.O.), 10 Amps (N.C.) @ 120/240 VAC
 Tungsten: 5 Amps (N.O.) @ 120/240 VAC
 Ballast: 20 Amps (N.O.), 3 Amps (N.C.) @ 120-277 VAC
 Motor: 1 HP (N.O.), ¼ HP (N.C.) @ 120 VAC
 Motor: 2 HP (N.O.), ½ HP (N.C.) @ 240 VAC

Pulse Feature:

2-circuit models feature 2-second pulse option for contactor and bell ringing applications

Auto DST:

Automatic adjustment for Daylight Saving Time

Battery Backup:

Two field-replaceable AAA batteries maintain date and accurate time for a minimum of 3 years. Batteries can be replaced when power to mechanism is activated.

Wiring Terminals:

#18 to #10 AWG wire

Minimum ON/OFF Time:

1 minute

Maximum ON/OFF Time:

6 days, 23 hours 59 minutes

Warranty:

Limited 1 year

Model Number	Circuits	Switch	Volts AC	Rating	Enclosure	Shipping Weight
ET1705C	1	SPST	120, 208, 240, 277	30 Amps	Type 1 Steel	2.9 lbs (1.3kg)
ET1705CPD82	1	SPST	120, 208, 240, 277	30 Amps	Type 3R Plastic	3.6 lbs (1.6kg)
ET1705CR	1	SPST	120, 208, 240, 277	30 Amps	Type 3R Steel	3.6 lbs (1.6kg)
ET1715C	1	SPDT	120, 208, 240, 277	20/10 Amps	Type 1 Steel	2.9 lbs (1.3kg)
ET1715CPD82	1	SPDT	120, 208, 240, 277	20/10 Amps	Type 3R Plastic	3.6 lbs (1.6kg)
ET1715CR	1	SPDT	120, 208, 240, 277	20/10 Amps	Type 3R Steel	3.6 lbs (1.6kg)
ET1725C*	2	SPST	120, 208, 240, 277	30 Amps	Type 1 Steel	2.9 lbs (1.3kg)
ET1725CPD82*	2	SPST	120, 208, 240, 277	30 Amps	Type 3R Plastic	3.6 lbs (1.6kg)
ET1725CR*	2	SPST	120, 208, 240, 277	30 Amps	Type 3R Steel	3.6 lbs (1.6kg)

*Can be wired as DPST

Specification

The time switch shall be of the 7-day electronic type, capable of permitting up to 28 setpoints or events weekly. The time switch shall provide a minimum ON or OFF time of 1 minute. Time switch to be powered by ___ (120)(208)(240)(277) VAC, ___ (50)(60) Hz power supply. The time switch mechanism shall be a snap-in design to provide easy mechanism removal for mounting the enclosure. The time switch enclosure shall be a _____(Type 1 Steel)(Type 3R Steel)(Type 3R Plastic) lockable enclosure that shall be painted with an electrostatic process to eliminate the potential for corrosion. The time switch shall provide clear terminal identification on a non-curling terminal insulator. A visual indicator shall be provided in the time switch for indicating output load status. Terminal connections shall be made using teeter-type terminal screws to provide secure connections for wire sizes up to #10 AWG. Switch configuration shall be _____ (SPST)(DPST) (SPDT) with a UL or CSA listed switch rating of:

(If SPST:)

- Resistive: 30 Amps @ 120/240 VAC
- Resistive: 20 Amps @ 28 VDC
- Inductive: 30 Amps @ 120/240 VAC
- Tungsten: 5 Amps @ 120/240 VAC
- Ballast: 20 Amps @ 120-277 VAC
- Motor: 1 HP @ 120 VAC
- Motor: 2 HP @ 240 VAC

(If SPDT:)

- Resistive: 20 Amps (N.O.), 10 Amps (N.C.) @ 120/240 VAC
- Inductive: 20 Amps (N.O.), 10 Amps (N.C.) @ 120/240 VAC
- Tungsten: 5 Amps (N.O.) @ 120/240 VAC
- Ballast: 20 Amps (N.O.), 3 Amps (N.C.) @ 120-277 VAC
- Motor: 1 HP (N.O.), ¼ HP (N.C.) @ 120 VAC
- Motor: 2 HP (N.O.), ½ HP (N.C.) @ 240 VAC

The time switch shall be UL or CSA listed under UL category 916 Energy Management Equipment and shall be Intermatic model _____(See Model Numbers Listed).

Diagrams

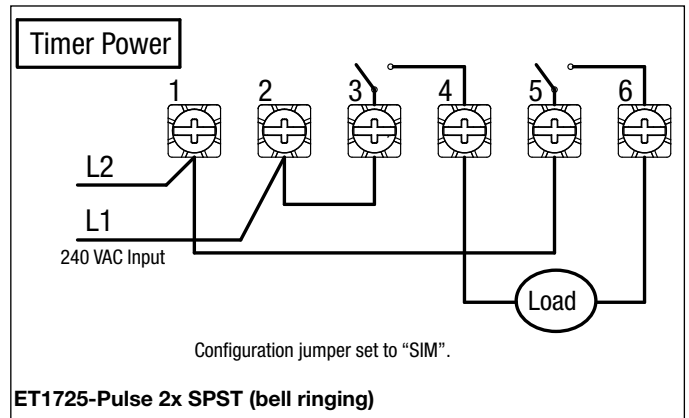
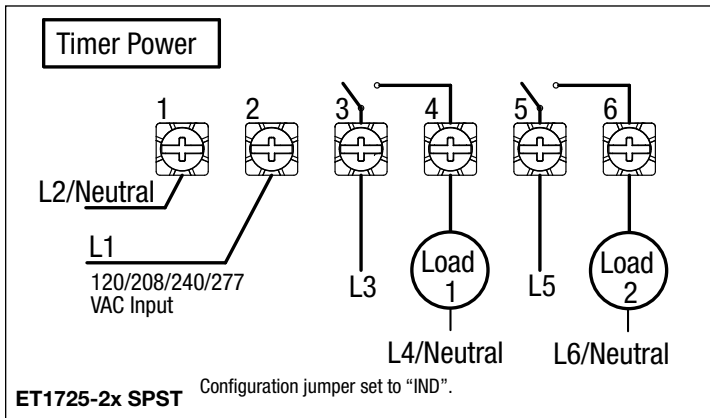
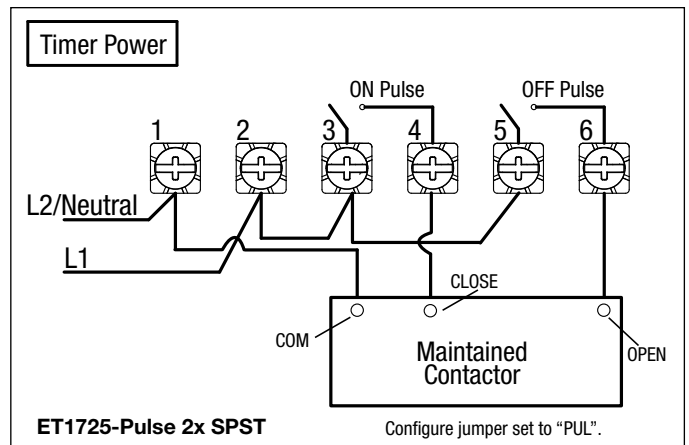
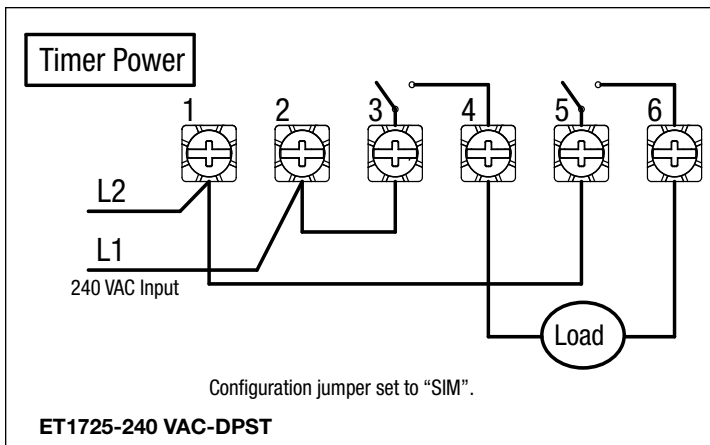
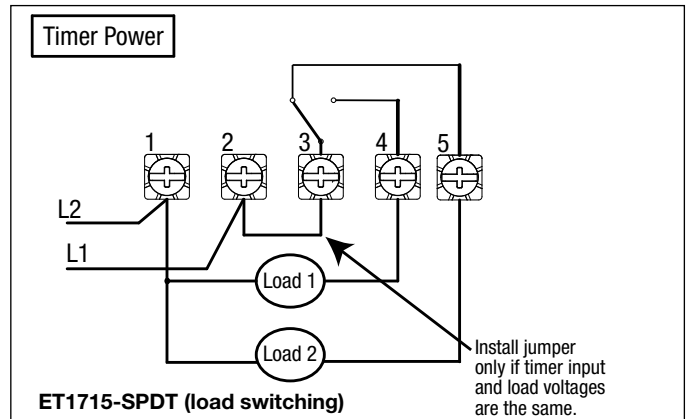
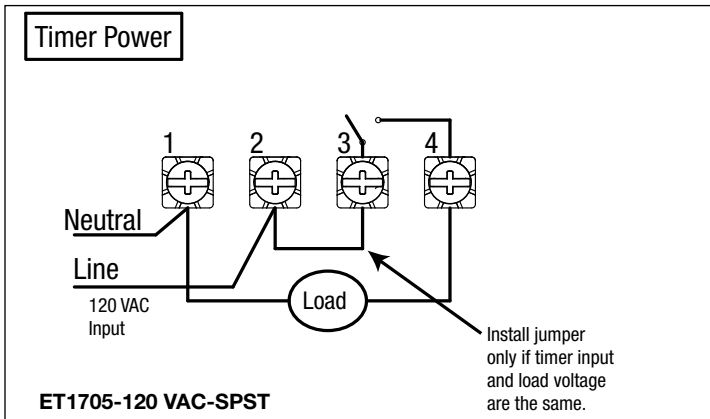

Notes
