

New Information

Meter Breakers

Contents

<i>Description</i>	<i>Page</i>
Residential Meter Breakers	
Residential Meter Breakers	2
Product Selection	3, 4
Box Styles	5
Typical Wiring Diagrams	6 – 13
Dimensions and Knockouts	14 – 18
Type CH Residential 300 Ampere and 400 Ampere "House Panels"	
Product Selection	19
Typical CH Wiring Diagrams	20
Dimensions and Knockouts	21
Type BR Residential 300 Ampere and 400 Ampere "House Panels"	
Product Selection	22
Typical BR Wiring Diagrams	23, 24
Dimensions and Knockouts	25



Meter Breaker Family

Residential Meter Breakers



Residential Meter Breakers

Product Description

A meter breaker is service entrance equipment that consists of a single meter socket and loadcenter (circuit breaker distribution section) or meter socket and main breaker combined in one enclosure. Sometimes called Combos, All-In-Ones, Meter Centers or Meter Mains these units are increasing in popularity as the socket and load-center or main breaker are located in one location, thus providing the contractor with a labor and material savings when installing.

Application Description

In addition to residential installations, meter breakers are equally applicable for rural service entrance, mobile homes, and construction site temporary power. Meter breakers are most often sold in the Western, Southwestern and Southeastern United States. The popularity of meter breakers is continuing to increase as more utilities deregulate and pass the responsibility of supplying watt-hour meter sockets on to the electrical contractor.

Application Considerations

We have the meter breaker to meet your application. Cutler-Hammer offers:

- Non-EUSERC.
- EUSERC/West Coast (Electrical Utility Service Equipment Requirements Committee).
- House Panels.
- Commercial Safety Sockets.

Non-EUSERC

The Cutler-Hammer line of Non-EUSERC meter breakers is designed for customers served by utilities that are not members of EUSERC.

EUSERC/West Coast

The Cutler-Hammer line of EUSERC approved devices adheres to the agreed upon standards. EUSERC utilities are predominately located in the Western United States, but some Eastern and Midwestern utilities are also members. **These units can also be used in many Non-EUSERC areas.**

House Panels

Meter breaker device rated at 300 – 400A. Applied in EUSERC and Non-EUSERC areas.

Commercial Safety Sockets

Applied in EUSERC and Non-EUSERC service areas and used in commercial applications.

Standards and Certifications

- UL Specification 414.
- UL File Number E52977.
- AEIC-EEI-NEMA Standards (MSJ-7).
- Meet EUSERC Utility requirements where noted.
- Documented Seismic Qualified — UBC and CBC Title 24.

Product Specifications

- Ratings single-phase, 3-wire, 120/240V AC.
- 100 through 225 ampere main breaker and main lug types.
- 10,000 amperes rms symmetrical short circuit rating.

Features, Benefits and Functions

- Both BR and CH type branch circuit breaker styles available.
- Meets latest NEC wire bending space requirements.
- Slotted sealing screws at hub with sealing provision provided.
- Surface units are supplied with mounting tabs.
- Semi-flush units are supplied with stucco flange.
- Meter socket ring landing will accept locking security rings.
- Overhead or underground service.
- Fifth jaw can be installed in the 3 o'clock or 9 o'clock position.
- Semi-flush with nail flange or surface mounting.
- Meter mounting and underground pull sections are utility sealable.
- Units are rated a minimum of 10,000 AIC; some units are 22,000 AIC.
- Numerous units supplied with center keyhole for ease of mounting.

Product Selection

Table 1. Combination Service Entrance Devices (Non-EUSERC)

Ampere Rating	Bypass	Service	AIC	Jaws	Distribution	Main	Branch Breaker Type	Catalog Number	Box Dimension ①	Information Pages	
										Wiring	Knockout
Ring Style Meter Mains (no distribution section included)											
100	None	OH	Ⓣ	4	None	Provision ②	None	WMB102RN	8	N/A	N/A
150	None	OH/UG	10k	4	None	CSR2150	None	MBB150BTSCR ③	13	13	18
200	None	OH/UG	10k	4	None	CSR2200	None	MBB200BTSCR ③	13	13	18
200	None	OH/UG	Ⓣ	4	None	Provision ④⑤	None	MBP200BTSCR ③	13	13	18
200	None	OH/UG	22k	4	None	CSR2200	None	CMBB200BTS ⑥⑦	3	7	15
Ringless Meter Mains (no distribution section included)											
150	None	OH/UG	10k	4	None	CSR2150	None	MBB150BTSC ⑥	13	13	18
200	None	OH/UG	10k	4	None	CSR2200	None	MBB200BTS	9	13	18
200	None	OH/UG	10k	4	None	CSR2200	None	MBB200BTSC ⑥	13	13	18
200	None	OH/UG	Ⓣ	4	None	Provision ④⑤	None	MBP200BTS	9	13	18
200	Horn	OH/UG	Ⓣ	5	None	Provision ④⑤	None	MBP200SD	11	13	18
200	Horn	OH/UG	Ⓣ	5	None	Provision ④⑤	None	MBP200BTSD	9	13	18
Ring Style All-In-Ones (includes distribution section)											
125	None	OH/UG	Ⓣ	4	Will accept maximum four 1-pole, two 2-pole, or two quad breakers	None — Refer to Distribution	BR BR	WMB1224SCN WMB1224SCR ⑥	1 1	Refer to drawing 96-5500	— —
125	None	OH/UG	Ⓣ	4							
125	None	OH/UG	Ⓣ	4	2/4	None — Refer to Distribution	CH CH	CMB24L125BTS ⑥⑦ CMB88B150BTS ⑥⑦	2 3	7 7	15 15
150	None	OH/UG	22k	4	8						
150	None	UG	22k	4	32/42	CSR2150	CH	CMB3242B150BS ⑥⑦	7	6	14
200	None	OH/UG	10k	4	4/8	BW2200 CSR2200 CSR2200	BR CH CH	MB48B200BTS ⑧⑨ CMB88B200BTS ⑧⑨⑦ CMB3242B200BS ⑥⑦	3 3 7	9 7 6	15 15 14
200	None	OH/UG	22k	4	8						
200	None	UG	22k	4	32/42						
Ringless All-In-Ones (includes distribution section)											
200	None	OH/UG	10k	4	8/16	BW2200 BW2200 Provision ④	BR BR BR	MB816B200BTS ⑧ MB816B200BTSCU ⑦⑥ MB816P200BTS ⑧	10 10 10	13 13 13	18 18 18
200	None	OH/UG	10k	4	8/16						
200	None	OH/UG	Ⓣ	4	8/16						
200	None	OH/UG	Ⓣ	4	8/16	Provision ④ Provision ④ Provision ④	BR BR BR	MB816P200BTSCU ⑦⑥ MB816P200STD ⑧ MB816P200BTSD ⑧	10 11 10	13 13 13	18 18 18
200	Horn	OH/UG	Ⓣ	5	8/16						
200	Horn	OH/UG	Ⓣ	5	8/16						
200	Horn	OH/UG	Ⓣ	5	8/16	Provision CSR2000	BR CH	MB816P200BTSCUD ⑦ CMB1212B200BTS ⑧⑦	10 10	13 11	18 16
200	None	OH/UG	10k	4	12/12						
200	Horn	OH/UG	22k	5	12/12						
200	None	OH/UG	Ⓣ	4	6 – 2 Pole	CSR2200 Main Lugs Main Lugs	CH CH CH	CMB1212B200BTSD ⑧⑦ CMB1212L200BTS ⑦ CMB1212L200BTSD ⑦	10 9 9	11 11 11	16 16 16
200	None	OH/UG	Ⓣ	4	6 – 2 Pole						
200	Horn	OH/UG	Ⓣ	5	6 – 2 Pole						
200	None	OH/UG	Ⓣ	4	12/12	Provision ④ Provision ④ Main Lugs	CH CH BR	CMB1212P200BTS ⑧⑦ CMB1212P200BTSD ⑧⑦ MB1212L200BTS	10 10 9	11 11 11	16 16 16
200	Horn	OH/UG	Ⓣ	5	12/12						
200	None	OH/UG	Ⓣ	4	6 – 2 Pole						
200	None	OH/UG	22k	4	24/24	CSR2200	CH	CMB2424B200BTS	10	11	16
200	Horn	OH/UG	Ⓣ	5	6 – 2 Pole	Main Lugs BW2200	BR BR	MB1212L200BTSD MB2040B200BTS	9 10	11 13	16 18
200	None	OH/UG	10k	4	20/40						
200	None	OH/UG	Ⓣ	4	20/40						
200	None	OH/UG	Ⓣ	4	20/40	Provision ④ Provision ④	BR BR	MB2040P200BTS MB2040P200SD	10 11	13 13	18 18
200	Horn	OH/UG	Ⓣ	5	20/40						
200	Horn	OH/UG	Ⓣ	5	20/40						

- ① See Page 5 for box details.
- ② Provision for main is provided. WMB style devices accept Main Breaker style BR, 2-Pole.
- ③ Panels are specifically designed for the Georgia Power Service Territory, but may be used in any service territory that has the same design requirements.
- ④ When a provision for main is provided, order one of the main breakers listed in Table 2. All panels are dual labeled to accept Types BW or CSR Main Breakers.
- ⑤ MCBK225 lug kit is needed for load side cable connection for Meter Mains. Please order separately.
- ⑥ Single cover design.
- ⑦ Copper bus.
- ⑧ Units come with feed-through lugs.
- ⑨ One-piece cover on utility side Florida approved.
- Ⓣ Per installed main breaker rating.

Table 2. Main Breaker Selection Chart

Maximum Ampere Rating	Catalog Number		
	10,000 AIC	22,000 AIC	
125	BW2125	BWH2125	CSR2125N
150	BW2150	BWH2150	CSR2150N
200	BW2200	BWH2200	CSR2200N
Load Side Lug Kit for BW and CSR Breakers. ⑤			MCBK225

⑤ When a provision for main is provided, order one of the main breakers listed in Table 2. All panels are dual labeled to accept Types BW or CSR Main Breakers.

Table 3. Combination Service Entrance Devices (EUSERC)

Ampere Rating	Bypass	Service	AIC	Jaws	Distri- bution	Main	Branch Breaker Type	Catalog Number		Box Dimension ①	Information Pages	
								Surface	Flush		Wiring	Knockout
Ring Style Meter Mains (no distribution section included)												
125	None	OH/UG	②	4	2/4	MLO	BR	MBE24L125BTS	MBE24L125BTF	2	9	15
125	None	OH/UG	②	4	2/4	MLO	CH	CMBE24L125BTS ⑤	CMBE24L125BTF ⑤	2	7	15
150	None	OH/UG	10k	4	None	BW2150	None	MBEB150BTS	MBEB150BTF	3	9	15
150	None	OH/UG	22k	4	None	CSR2150N	None	CMBEB150BTS ⑤	CMBEB150BTF ⑤	3	7	15
200	None	OH/UG	10k	4	None	BW2200	None	MBEB200BTS	MBEB200BTF	3	9	15
200	None	OH/UG	22k	4	None	CSR2200N	None	CMBEB200BTS ⑤	CMBEB200BTF ⑤	3	7	15
200	None	OH/UG	②	4	2/4	MLO	BR	MBE24L200BTS	MBE24L200BTF	3	9	15
200	None	OH/UG	②	4	2/4	MLO	CH	CMBE24L200BTS ⑤	CMBE24L200BTF ⑤	3	7	15
200	None	OH/UG	②	4	None	Provision	None	MBEP200BTS ⑥	N/A	3	9	15
Ring Style All-In-Ones (includes distribution section)												
100	None	OH/UG	10k	4	12/24	BR2100	BR	MBE1224B100BTS	MBE1224B100BTF	2	7	15
100	None	UG	10k	4	14/28	BR2100	BR	MBE1428B100BS	MBE1428B100BF	4	8	14
100	None	UG	10k	4	22	CH2100X	CH	CMBE2222B100BS ⑤	CMBE2222B100BF ⑤	5	6	14
100	None	OH	10k	4	12/24	BR2100	BR	MBE1224B100TS	MBE1224B100TF ③	9	13	16
125	None	OH/UG	10k	4	12/24	BR2125	BR	MBE1224B125BTS	MBE1224B125BTF	2	7	15
125	None	OH	10k	4	12/24	BR2125	BR	MBE1224B125TS	MBE1224B125TF ③	9	13	16
125	None	UG	10k	4	14/28	BR2125	BR	MBE1428B125BS	MBE1428B125BF	4	8	14
125	None	UG	10k	4	18/36	BR2125	BR	MBE1836B125BS	MBE1836B125BF	5	8	14
125	None	UG	10k	4	22	CH2125X	CH	CMBE2222B125BS ⑤	CMBE2222B125BF ⑤	5	6	14
150	None	OH/UG	22k	4	8	CSR2150N	CH	CMBE88B150BTS ④⑤	CMBE88B150BTF ④⑤	3	7	15
150	None	UG	22k	4	32/42	CSR2150N	CH	CMBE3242B150BS ⑤	CMBE3242B150BF ⑤	7	6	14
150	None	UG	10k	4	20/40	BW2150	BR	MBE2040B150BS	MBE2040B150BF	6	8	14
150	None	OH/UG	10k	4	4/8	BW2150	BR	MBE48B150BTS	MBE48B150BTF	3	9	15
150	None	OH/UG	10k	4	8	BW2150	BR	MBE88B150BTS	MBE88B150BTF	3	9	15
200	None	OH/UG	10k	4	4/8	BW2200	BR	MBE48B200BTS ④	MBE48B200BTF ④	3	9	15
200	None	OH/UG	22k	4	8	CSR2200N	CH	CMBE88B200BTS ④⑤	CMBE88B200BTF ④⑤	3	7	15
200	None	OH/UG	10k	4	8	BW2200	BR	MBE88B200BTS	MBE88B200BTF	3	9	15
200	None	OH/UG	②	4	8/16	Provision	BR	MBE816P200TSCU ⑤⑥	N/A	10	10	16
200	None	OH	②	4	8/16	Provision	BR	MBE816P200TS ④⑥	N/A	10	10	16
200	None	OH	②	4	6 – 2 Pole	Main Lug	CH	CMBE1212L200TS ⑤	N/A	9	10	16
200	None	UG	②	4	6 – 2 Pole	Main Lug	CH	CMBE1212L200BS ⑤	CMBE1212L200BF ⑤	5	6	14
200	None	OH	②	4	6 – 2 Pole	Main Lug	BR	MBE1212L200TS	N/A	9	10	16
200	None	UG	②	4	6 – 2 Pole	Main Lug	BR	MBE1212L200BS	MBE1212L200BF	5	8	14
200	None	OH	10k	4	20/40	BW2200	BR	MBE2040B200TS	MBE2040B200TF	10	10	16
200	None	UG	10k	4	20/40	BW2200	BR	MBE2040B200BS	MBE2040B200BF	6	8	14
200	None	OH	②	4	20/40	Provision	BR	MBE2040P200TS ⑥	MBE2040P200TF ③⑥	10	10	16
200	None	UG	22k	4	32/42	CSR2200N	CH	CMBE3242B200BS ⑤	CMBE3242B200BF ⑤	7	6	14
200	None	OH/UG	10k	4	40	BW2200	BR	MBE4040B200BTS	MBE4040B200BTF ③	12	12	17
200	None	OH/UG	22k	4	42	CSR2200N	CH	CMBE4242B200BTS ⑤	CMBE4242B200BTF ③⑤	12	12	17
200	None	OH/UG	10k	4	20/40	BW2200	BR	WMB202040S	WMB202040B	—	—	—
200	None	OH/UG	10k	4	4/8	BW2200	BR	WMB2048SLB ⑦	N/A	—	—	—
225	None	OH/UG	10k	4	20/40	BW2225	BR	WMB222040S	WMB222040F	—	—	—
225	None	UG	22k	4	32/42	CSR2225N	CH	CMBE3242B225BS ⑤	CMBE3242B225BF ⑤	7	6	14

- ① See Page 5 for box details.
- ② Interrupting rating is dependent on the main breaker that is installed.
- ③ Semi flush flange, not full stucco flange
- ④ Units come with feed-through lugs.
- ⑤ Unit has copper bus.
- ⑥ When a provision for main is provided, order one of the main breakers listed in Table 4. All panels are dual labeled to accept Types BW or CSR Main Breakers.
- ⑦ Use WMB70SMK if second main kit is needed.

Table 4. Main Breaker Selection Chart

Maximum Ampere Rating	Catalog Number		
	10,000 AIC	22,000 AIC	
125	BW2125	BWH2125	CSR2125N
150	BW2150	BWH2150	CSR2150N
200	BW2200	BWH2200	CSR2200N
Load Side Lug Kit for BW and CSR Breakers. ⑧			MCBK225

- ⑧ When a provision for main is provided, order one of the main breakers listed in Table 2. All panels are dual labeled to accept Types BW or CSR Main Breakers.

Box Styles

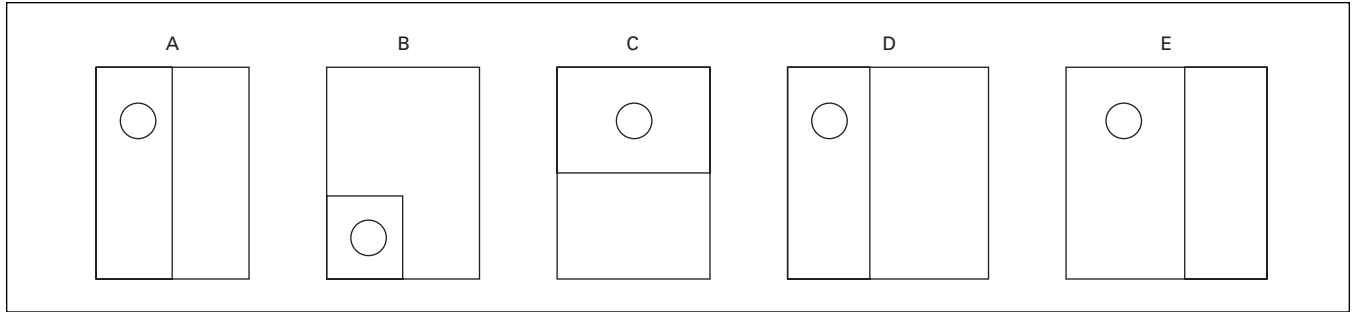

Figure 1. Five Different Styles (Shapes) of Product

Table 5. Box Dimensions

Box Number	Dimensions in Inches			Box Style
	Height	Width	Depth	
1	12-1/2 (317.5)	14-7/16 (366.7)	4 (101.6)	A
2	23-7/8 (606.4)	14-7/16 (366.7)	5-3/8 (136.5)	A
3	28-3/8 (720.7)	14-7/16 (366.7)	5-3/8 (136.5)	A
4	34-1/8 (866.8)	14-7/16 (366.7)	5-3/8 (136.5)	B
5	36-1/8 (917.6)	14-7/16 (366.7)	5-3/8 (136.5)	B
6	43-3/8 (1101.7)	14-7/16 (366.7)	5-3/8 (136.5)	B
7	46-7/8 (1190.6)	14-7/16 (366.7)	5-3/8 (136.5)	B
8	19-3/4 (501.7)	7-1/2 (190.5)	4 (101.6)	C
9	25-3/8 (644.5)	14-7/16 (366.7)	5-3/8 (136.5)	C
10	32-3/8 (822.3)	14-7/16 (366.7)	5-3/8 (136.5)	C
11	36-5/8 (930.3)	14-7/16 (366.7)	5-3/8 (136.5)	C
12	34-3/8 (873.1)	22 (558.8)	5-3/8 (136.5)	D
13	19-3/4 (501.7)	14-7/16 (366.7)	5-3/8 (136.5)	E

Table 6. Meter Breaker Parts

Description	Catalog Number
5th Jaw Kits	
Compact and Standard Styles (MB & CMB) WMB Style	1MM5JKOP WMB5J
Manual Bypass Kits	
Ring Style Units Only (MB)	1MMBPM200
Horn Bypass Kits	
Ringless Style Units Only (MB & CMB)	1MMBPH

Table 7. Wire Size Chart

Main	Wire Size Range Cu/Al 60°C or 75°C for Line Terminals
BR250 BR260 BR270	#14 – 4 kcmil #4 – 1/0 kcmil #4 – 1/0 kcmil
BR280 BR290 BR2100	#4 – 1/0 kcmil #4 – 1/0 kcmil #4 – 1/0 kcmil
BW2125 BW2150 BW2200	#2 – 300 kcmil #2 – 300 kcmil #2 – 300 kcmil
BWH2125 BWH2150 BWH2200	#2 – 300 kcmil #2 – 300 kcmil #2 – 300 kcmil
CSR2125N CSR2150N CSR2200N	#1/0 – 250 kcmil #1/0 – 250 kcmil #1/0 – 250 kcmil
125A Main Lugs 200A Main Lugs MCBK225	— — #2 – 300 kcmil

Table 8. Wire Size is Determined by the Circuit Breaker Installed in the Enclosure. Maximum Wire Size and Ampere Rating is Determined as Follows:

Wire/Application	Maximum	
	Wire Size	Ampere Rating
Aluminum — Standard	250 kcmil	200
Aluminum — Service Entrance	250 kcmil	225
Copper — Standard and Service Entrance	250 kcmil	225

Table 9. Hub Selection Chart

Hub Size Dimensions in Inches (mm)	Catalog Number
1 (25.4) 1-1/4 (31.8) 1-1/2 (38.1)	DS100H2 DS125H2 DS150H2
2 (50.8) 2-1/2 (63.5) 3 (76.2)	DS200H2 DS250H2 DS300H2

Typical Wiring Diagrams (Residential Meter Breakers)

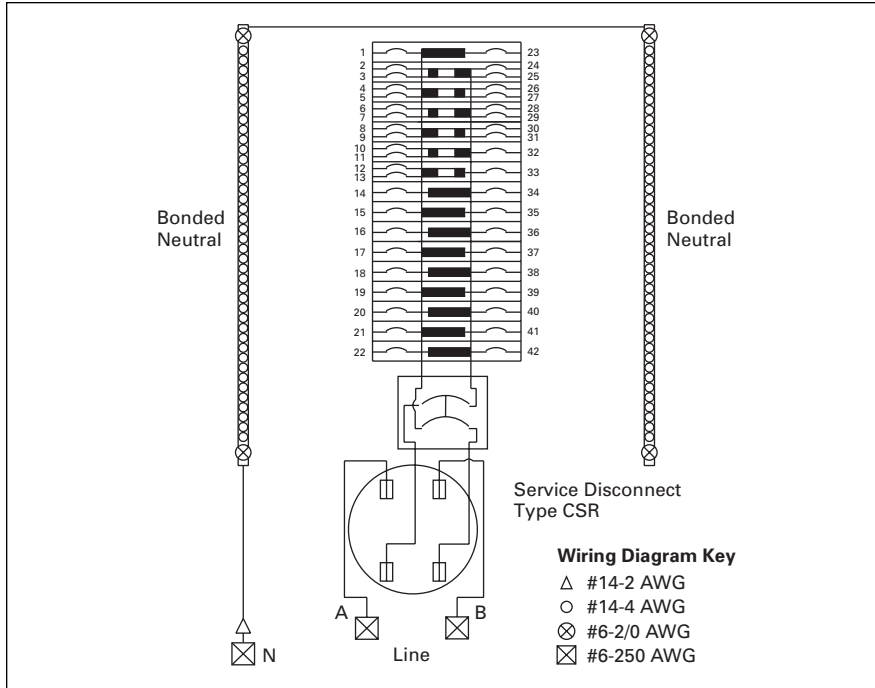

Figure 2. Catalog Numbers – CMB3242B200BS, CMBE3242B150BS, CMBE3242B150BF, CMBE3242B200BS, CMBE3242B200BF, CMBE3242B225BS, CMBE3242B225BF, CMB3242B150BS and CMB3242B200BS

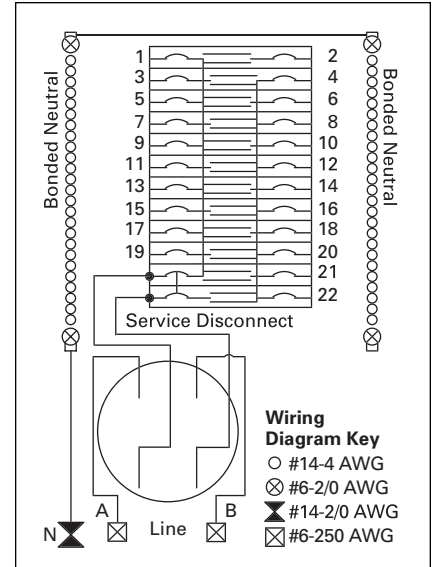

Figure 3. Catalog Numbers – CMBE2222B125BS, CMBE2222B125BF, CMBE2222B100BS and CMBE2222B100BF

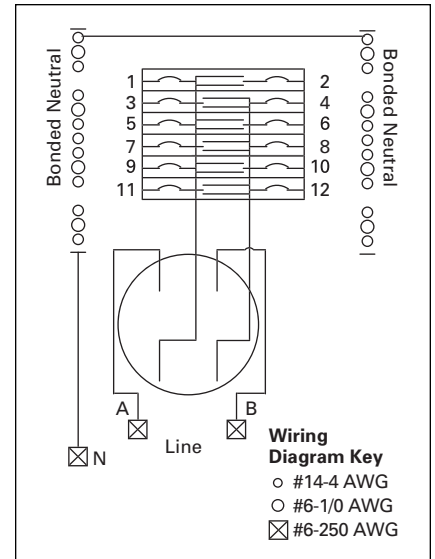

Figure 4. Catalog Numbers – CMBE1212L200BS and CMBE1212L200BF

Typical Wiring Diagrams (Residential Meter Breakers)

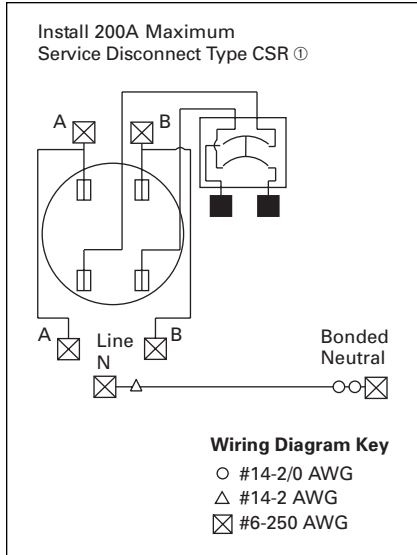

Figure 5. Catalog Numbers – CMBB200BTS, CMBE150BTF, CMBE150BTS, CMBE200BTF and CMBE200BTS

① Factory installed MCBK225 Kit for C/B load lugs.

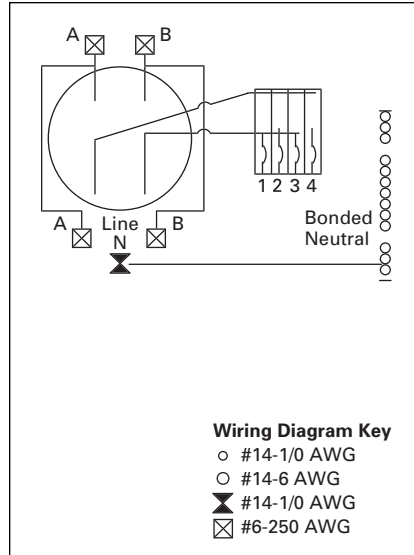

Figure 7. Catalog Numbers – CMBE24L125BTS, CMBE24L125BTF and CMB24L125BTS

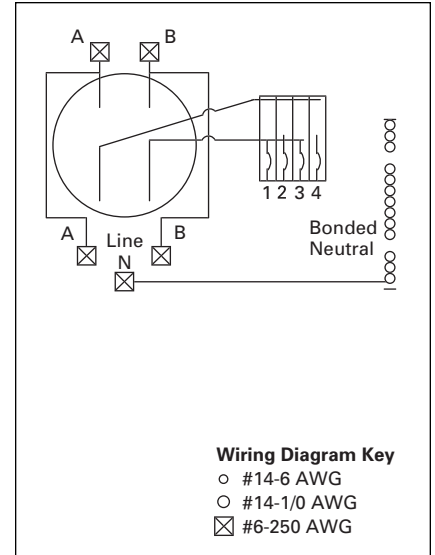

Figure 9. Catalog Numbers – CMBE24L200BTS and CMBE24L200BTF

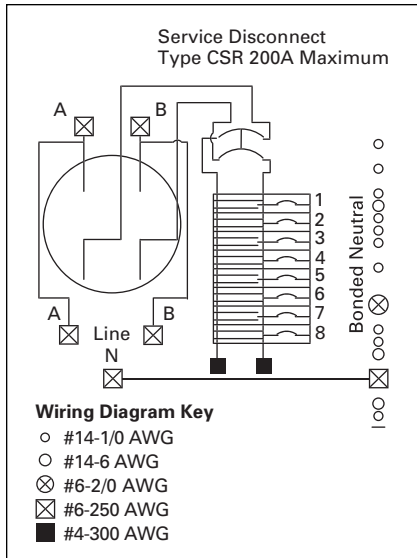

Figure 6. Catalog Numbers – CMBE88B200BTS, CMBE88B200BTF, CMBE88B200BTS, CMBE88B150BTS, CMBE88B150BTS and CMBE88B150BTF

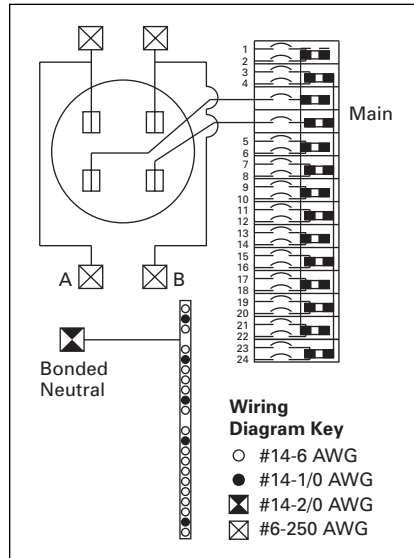

Figure 8. Catalog Numbers – MBE1224B100BTS, MBE1224B100BTF, MBE1224B125BTS and MBE1224B125BTF

Typical Wiring Diagrams (Residential Meter Breakers)

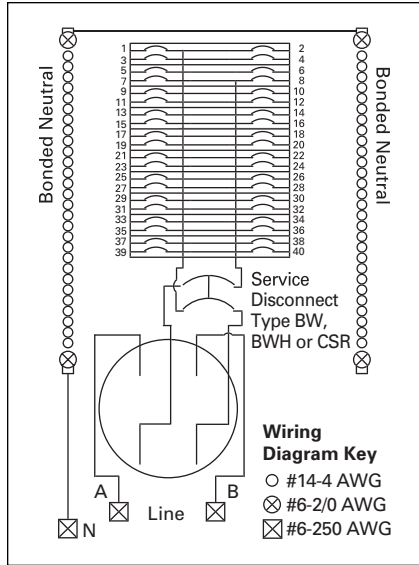

Figure 10. Catalog Numbers – MBE2040B150BS, MBE2040B150BF, MBE2040B200BS and MBE2040B200BF

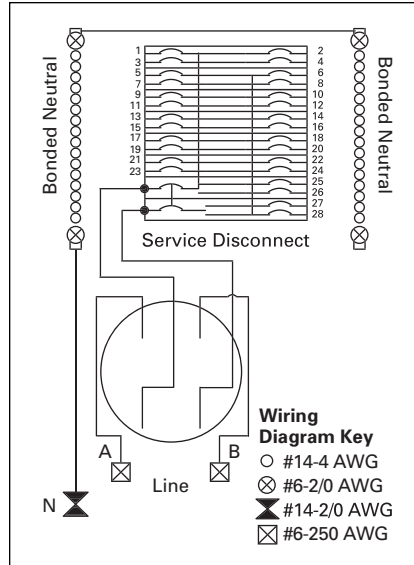

Figure 12. Catalog Numbers – MBE1428B100BS, MBE1428B100BF, MBE1428B125BS and MBE1428B125BF

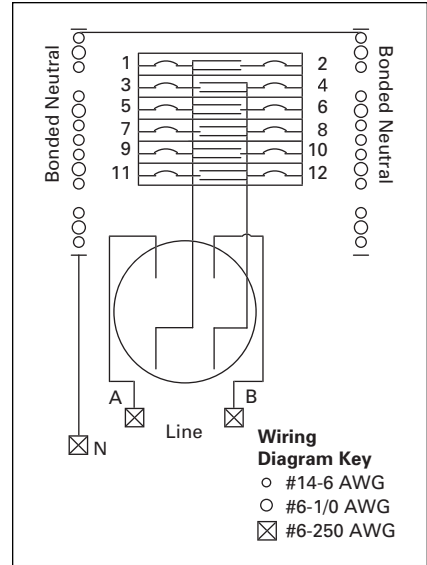

Figure 13. Catalog Numbers – MBE1212L200BS and MBE1212L200BF

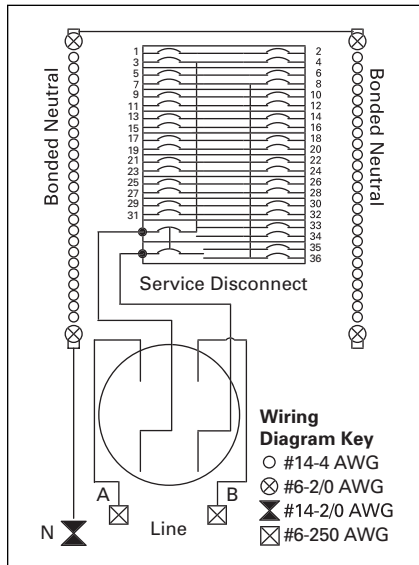

Figure 11. Catalog Numbers – MBE1836B125BS and MBE1836B125BF

Typical Wiring Diagrams (Residential Meter Breakers)

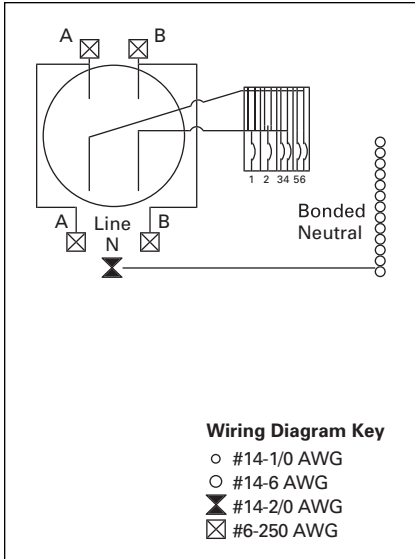

Figure 14. Catalog Numbers – MBE24L125BTS and MBE24L125BTF

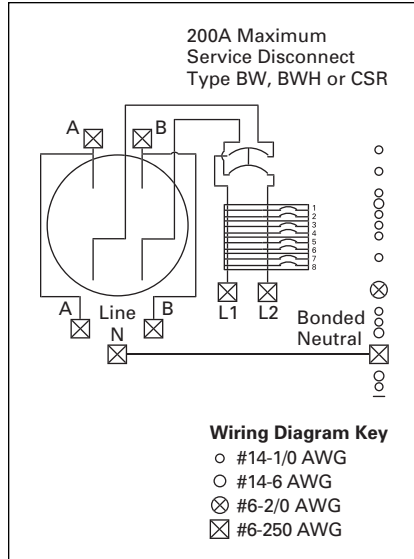

Figure 16. Catalog Numbers – MBE48B150BTS, MBE48B150BTF, MBE48B200BTS, MBE48B200BTF and MB48B200BTS

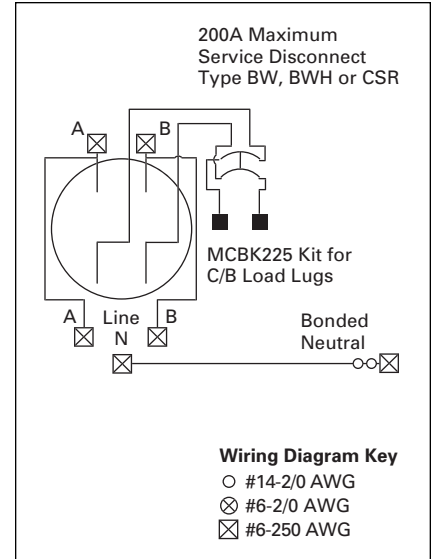

Figure 18. Catalog Numbers – MBEP200BTS, MBEB200BTS, MBEB200BTF, MBEB150BTS and MBEB150BTF

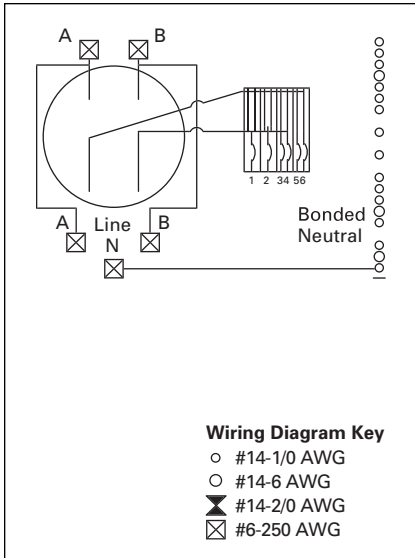

Figure 15. Catalog Numbers – MBE24L200BTS and MBE24L200BTF

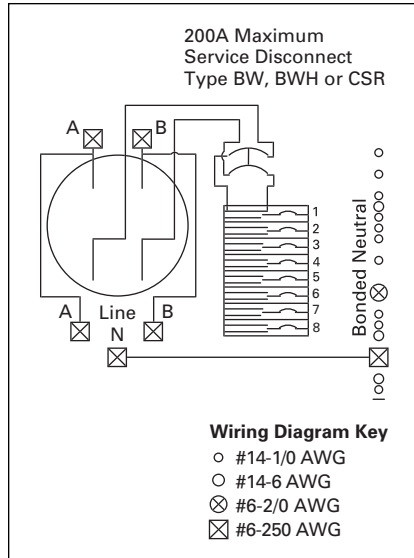

Figure 17. Catalog Numbers – MBE88B200BTS, MBE88B200BTF, MBE88B150BTS and MBE88B150BTF

Typical Wiring Diagrams (Residential Meter Breakers)

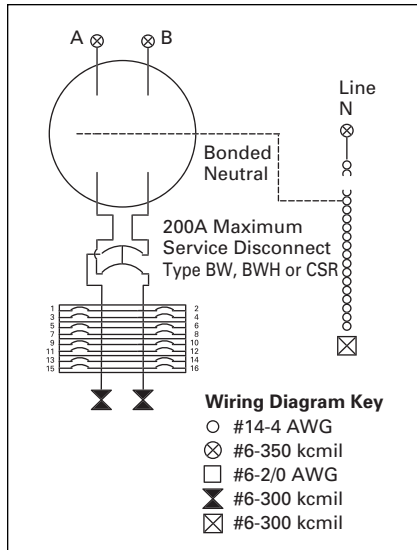

Figure 19. Catalog Numbers – MB816B200BTSCU, MBE816P200TS and MBE816P200TSCU

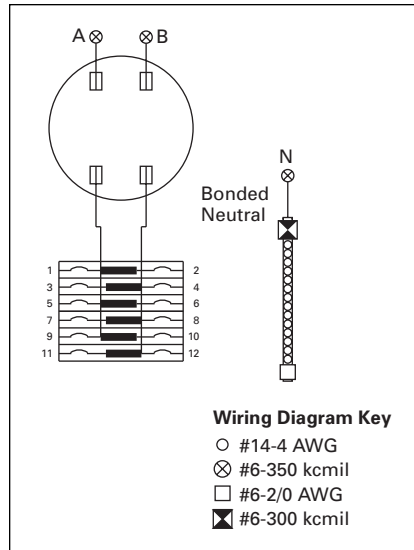

Figure 21. Catalog Number – MBE1212L200TS

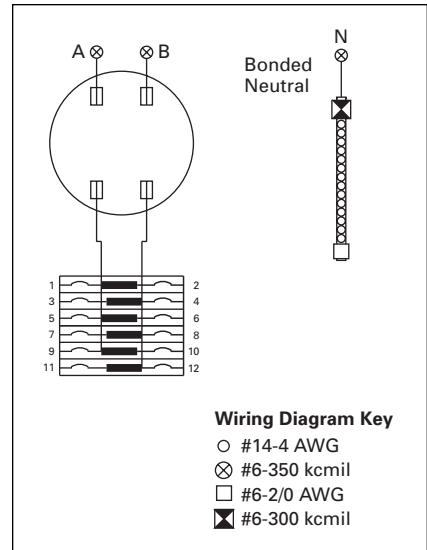

Figure 22. Catalog Number – CMBE1212L200TS

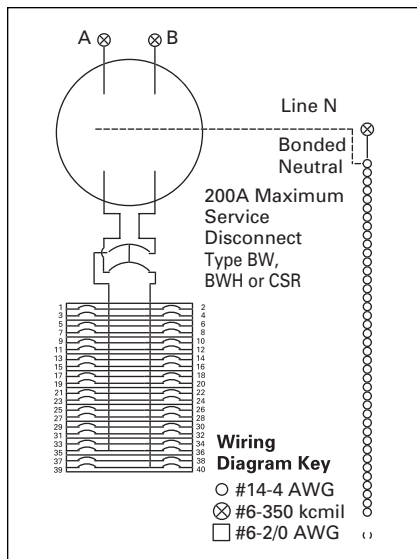

Figure 20. Catalog Numbers – MB2040P200BTSD, MBE2040P200TS, MBE2040P200TF, MBE2040B200TS, MBE2040B200TF

Typical Wiring Diagrams (Residential Meter Breakers)

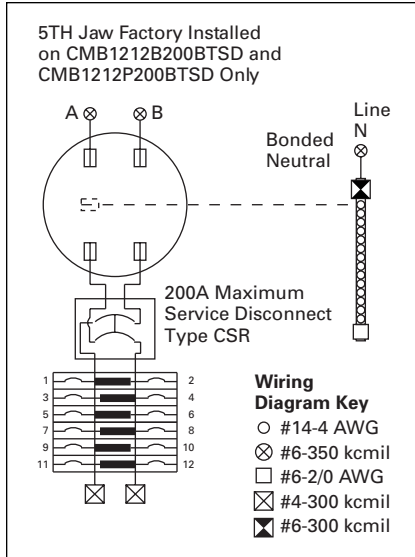

Figure 23. Catalog Numbers – CMB1212P200BTSD and CMB1212P200BTS

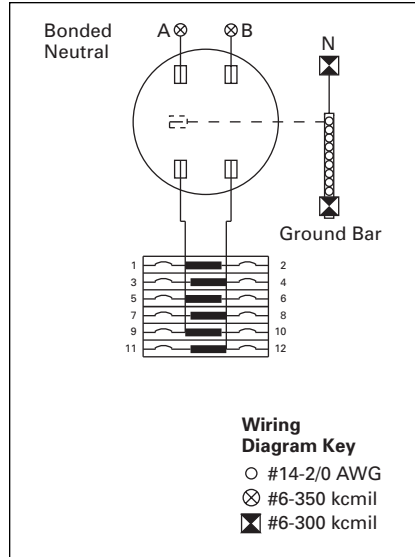

Figure 25. Catalog Numbers – MB1212L200BTS and MB1212L200BTSD

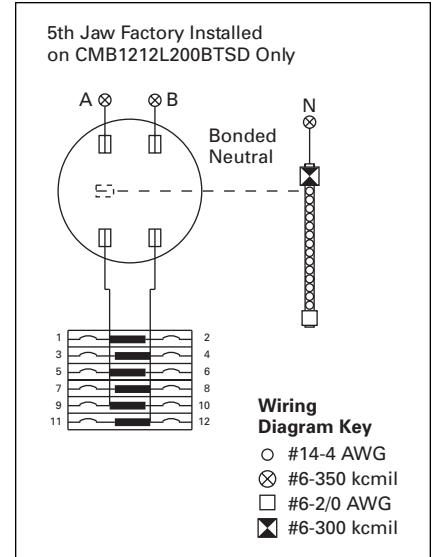

Figure 27. Catalog Numbers – CMB1212L200BTSD and CMB1212L200BTS

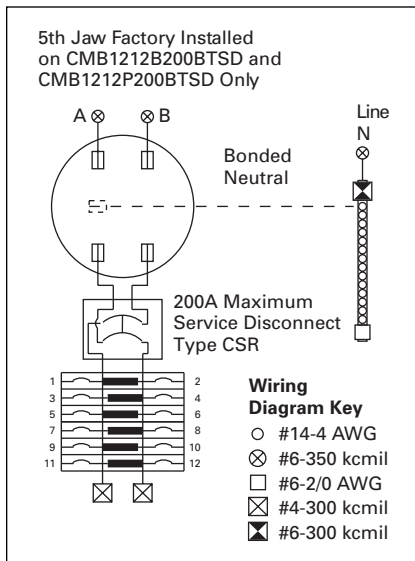

Figure 24. Catalog Numbers – CMB1212B200BTS and CMB1212B200BTSD

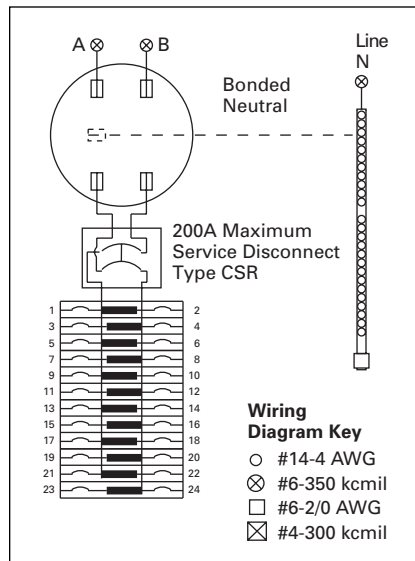

Figure 26. Catalog Numbers – CMB2424B200BTS

Typical Wiring Diagrams (Residential Meter Breakers)

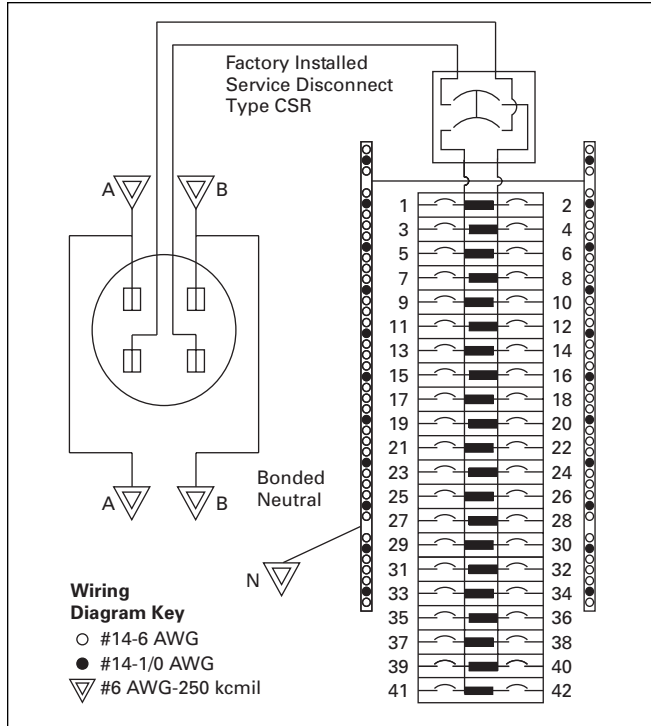

Figure 28. Catalog Numbers – CMBE4242B200BSH, CMBE4242B200BTS and CMBE4242B200BTF

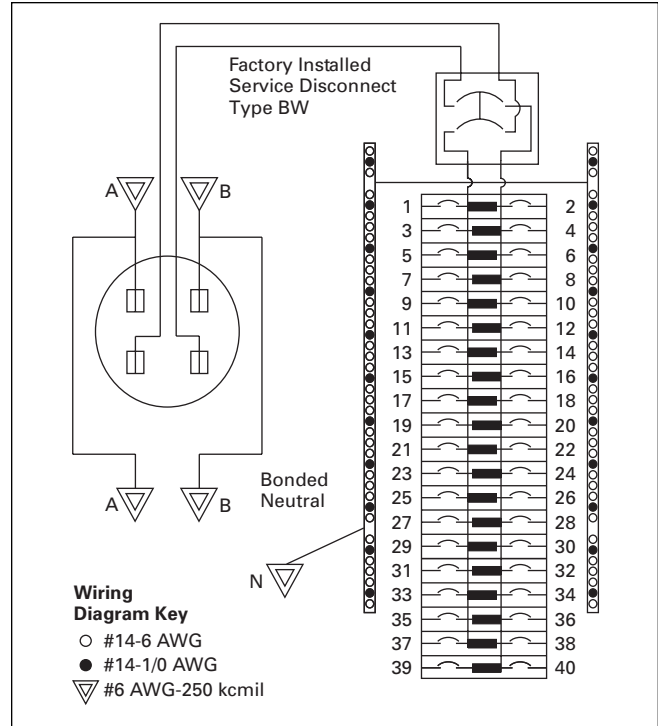

Figure 29. Catalog Numbers – MBE4040B200BTF, MBE4040B200BTS and MBE4040B200BSH

Typical Wiring Diagrams (Non-EUSERC Meter Breaker Design)

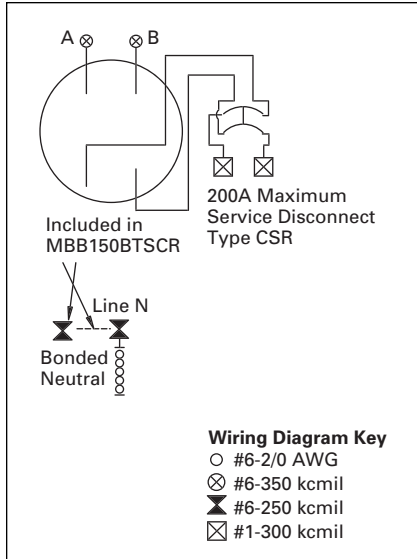

Figure 30. Catalog Numbers – MBB150BTSC, MBB150BTSCR, MBB200BTSCR, MBP200BTSCR and MBB200BTSC

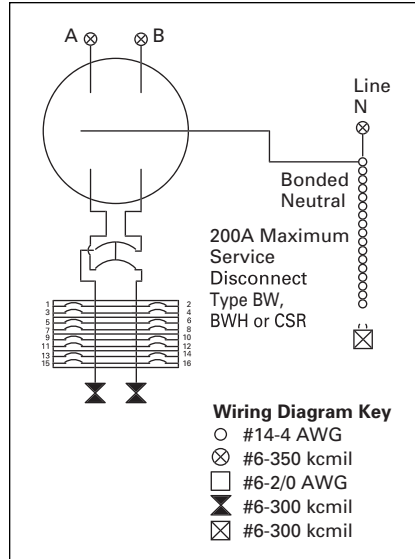

Figure 32. Catalog Numbers – MB816P200STD, MB816B200BTS, MB816B200BTSCU, MB816P200BTS, MB816P200BTSCU, MB816P200BTSD and MB816P200BTSCUD

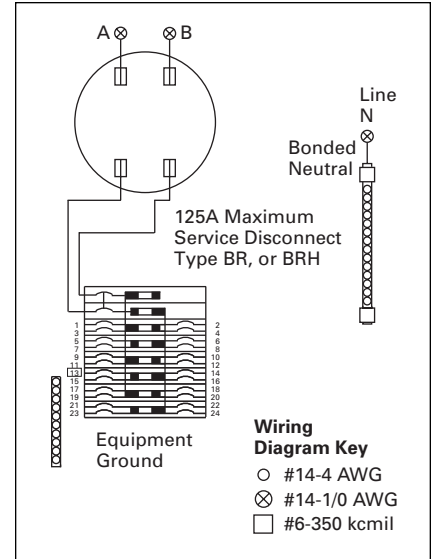

Figure 34. Catalog Numbers – MBE1224B125TS, MBE1224B125TF, MBE1224B100TS and MBE1224B100TF

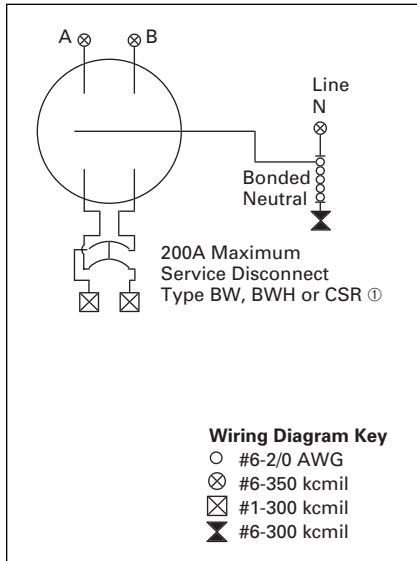

Figure 31. Catalog Numbers – MBP200SD, MBB200BTS, MBP200BTS and MBP200BTSD

① Use MCBK225 for C/B Load Lugs.

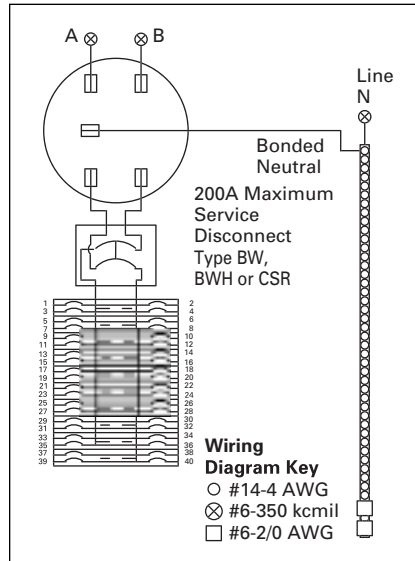

Figure 33. Catalog Numbers – MB2040P200SD, MB2040B200BTS, MB2040P200BTS and MB2040P200BTSD

Dimensions and Knockouts (Residential Meter Breakers) — Dimensions in Inches (mm)

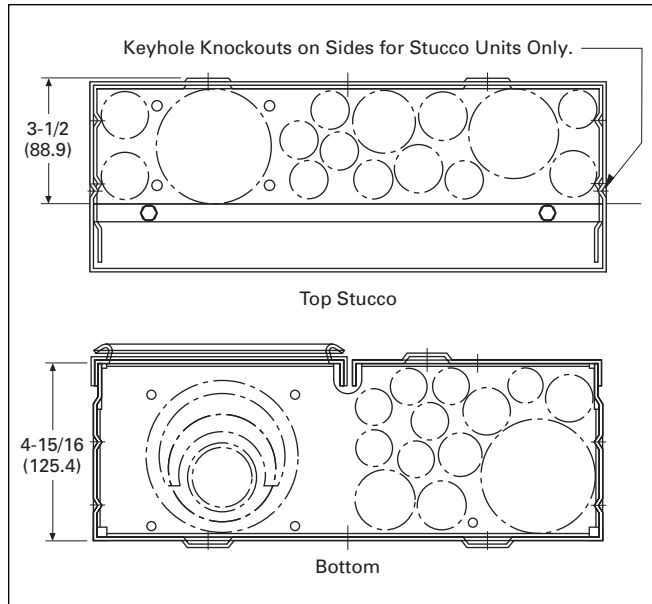

Figure 35. Knockouts for Stucco and Surface Units Catalog Numbers – CMBE3242B150BF, CMBE3242B200BF, CMBE3242B225BF, CMBE2222B100BF, CMBE2222B125BF, CMBE1212L200BF, MBE2040B200BF, MBE2040B150BF, MBE1428B100BF, MBE1428B125BF, MBE1212L200BF and MBE1836B125BF

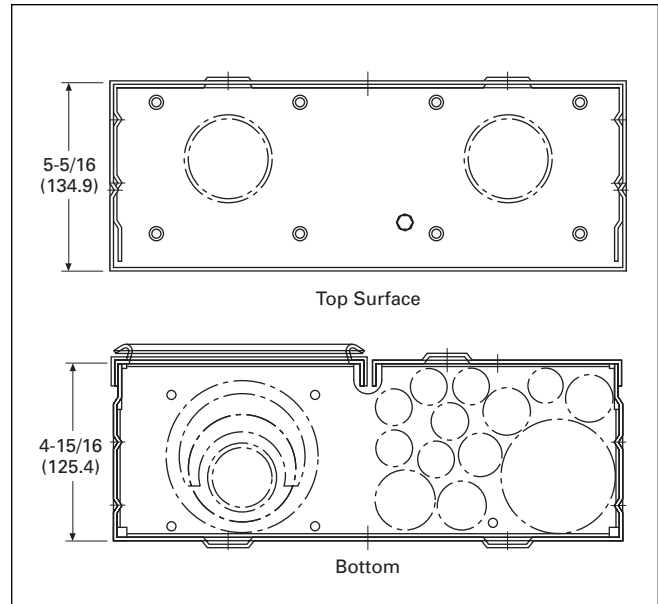

Figure 36. Knockouts for Stucco and Surface Units Catalog Numbers – CMBE3242B150BS, CMBE3242B200BS, CMBE3242B225BS, CMBE2222B100BS, CMBE2222B125BS, CMBE1212L200BS, MBE2040B200BS, MBE2040B150BS, MBE1428B100BS, MBE1428B125BS, MBE1212L200BS, MBE1836B125BS, CMB3242B150BS and CMB3242B200BS

Table 10. Top Endwall (Surface)

Hub Provision
DS100H2 DS125H2 DS150H2
DS200H2 DS250H2 DS300H2 DS900AP (Adapter Plate if using DS ___H1 hubs only) ①

① Use when DS H1 Type 1, 1-1/4 and 1-1/2-inch hubs are needed.

Table 11. Top Endwall (Stucco)

Knockout Size (Dimensions in Inches)	Quantity
1-1/4, 1-1/2, 2, 2-1/2	1
1, 1-1/4, 1-1/2	1
1/2, 3/4, 1	1
1/2, 3/4	5
1/2	7

Table 12. Bottom Endwall

Knockout Size (Dimensions in Inches)	Quantity
1/2,	7
1/2, 3/4	4
1/2, 3/4, 1	1
1, 1-1/4, 1-1/2, 2	1
1-1/4, 1-1/2, 2, 2-1/2, 3	1

Dimensions and Knockouts (Residential Meter Breakers) — Dimensions in Inches (mm)

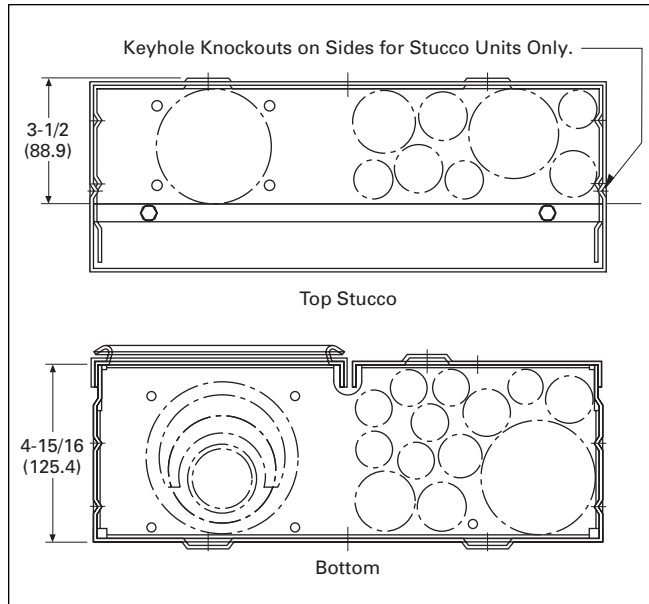

Figure 37. Knockouts for Stucco and Surface Units Catalog Numbers – CMBE24L200BTF, CMBE24L125BTF, CMBEB200BTF, CMBEB150BTF, CMBE88B150BTF, CMBE88B200BTF, MBE24L125BTF, MBE24L200BTF, MBE48B150BTF, MBE48B200BTF, MBE88B150BTF, MBE88B200BTF, MBEB150BTF, MBEB200BTF, MBE1224B100BTF and MBE1224B125BTF

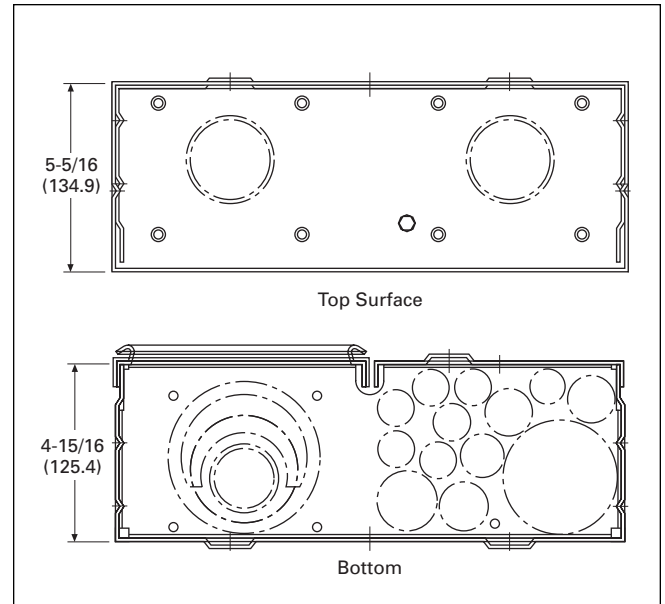

Figure 38. Knockouts for Stucco and Surface Units Catalog Numbers – CMBB200BTS, CMBE24L125BTS, CMB24L125BTS, CMBE24L200BTS, CMBEB200BTS, CMBEB150BTS, CMBE88B150BTS, CMBE88B200BTS, MBE24L125BTS, MBE24L200BTS, MBE48B150BTS, MBE48B200BTS, MBE88B150BTS, MBE88B200BTS, MBEB150BTS, MBEB200BTS, MBEP200BTS, MBE1224B100BTS, MBE1224B125BTS, CMB88B150BTS, CMB88B200BTS and MB48B200BTS

Table 13. Top Endwall (Surface)

Hub Provision
DS100H2 DS125H2 DS150H2
DS200H2 DS250H2 DS300H2 DS900AP (Adapter Plate) ①

① Use when DS H1 Type 1, 1-1/4 and 1-1/2-inch hubs are needed.

Table 14. Top Endwall (Stucco)

Knockout Size (Dimensions in Inches)	Quantity
1-1/4, 1-1/2, 2, 2-1/2	1
1, 1-1/4, 1-1/2	1
1/2, 3/4, 1	1
1/2, 3/4	3
1/2	3

Table 15. Bottom Endwall

Knockout Size (Dimensions in Inches)	Quantity
1/2	7
1/2, 3/4	4
1/2, 3/4, 1	1
1, 1-1/4, 1-1/2, 2	1
1-1/4, 1-1/2, 2, 2-1/2, 3	1

Dimensions and Knockouts (Residential Meter Breakers) — Dimensions in Inches (mm)

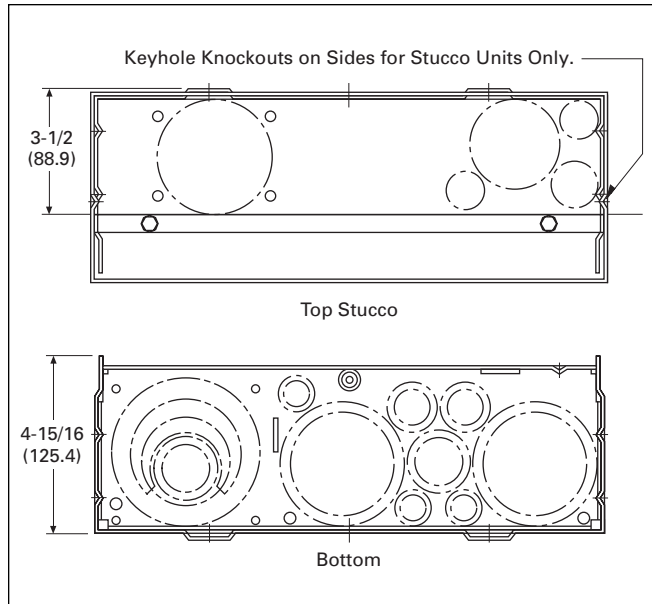

Figure 39. Knockouts for Stucco and Surface Units Catalog Numbers – MBE1224B100TF, MBE1224B125TF and MBE2040P200TF

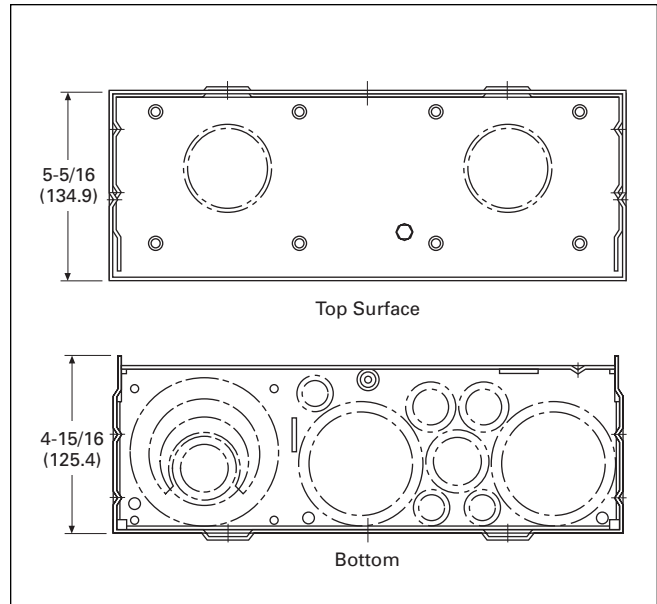

Figure 40. Knockouts for Stucco and Surface Units Catalog Numbers – MBE1224B100TS, MBE1224B125TS, MBE816P200TS, MBE816P200TSCU, MBE2040P200TS, MBE1212L200TS, CMBE1212L200TS, CMB1212P200BTS, CMB1212P200BTSD, CMB1212B200BTS, CMB1212B200BTSD, MB1212L200BTS, MB1212L200BTSD, CMB1212L200BTS and CMB1212L200BTSD

Table 16. Top Endwall (Surface)

Hub Provision
DS100H2 DS125H2 DS150H2
DS200H2 DS250H2 DS300H2 DS900AP (Adapter Plate) ①

① Use when DS H1 Type 1, 1-1/4 and 1-1/2-inch hubs are needed.

Table 17. Top Endwall (Stucco)

Knockout Size (Dimensions in Inches)	Quantity
1-1/4, 1-1/2, 2, 2-1/2	1
1, 1-1/4, 1-1/2	1
1/2, 3/4, 1	1
1/2, 3/4	5
1/2	7

Table 18. Bottom Endwall

Knockout Size (Dimensions in Inches)	Quantity
1/2	7
1/2, 3/4	4
1/2, 3/4, 1	1
1, 1-1/4, 1-1/2, 2	1
1-1/4, 1-1/2, 2, 2-1/2, 3	1

Dimensions and Knockouts (Residential Meter Breakers) — Dimensions in Inches (mm)

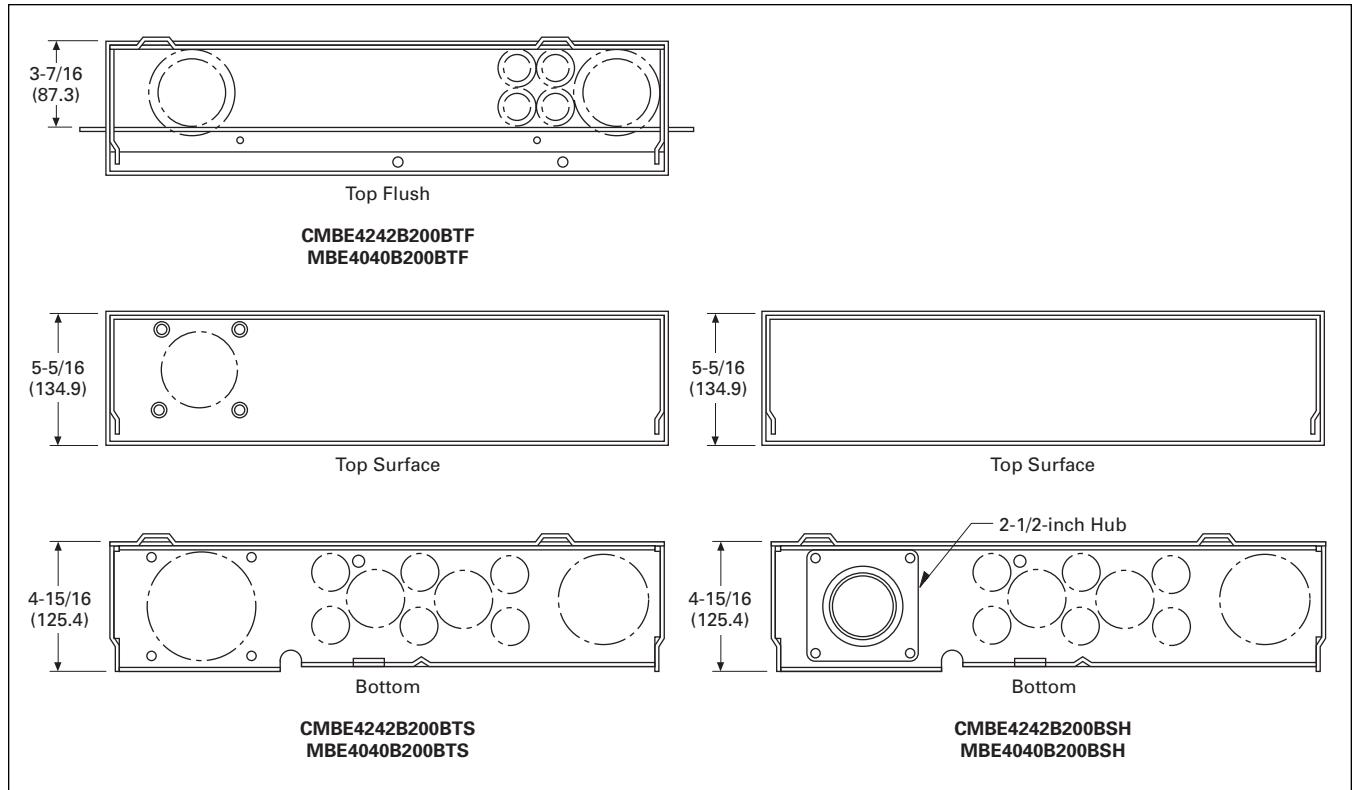

Figure 41. Knockouts for Stucco and Surface Units

Table 19. Top Endwall (Surface)

Hub Provision
DS100H2
DS125H2
DS150H2
DS200H2
DS250H2
DS300H2
DS900AP (Adapter Plate) ①

① Use when DS H1 Type 1, 1-1/4 and 1-1/2-inch hubs are needed.

Table 20. Top Endwall (Stucco)

Knockout Size (Dimensions in Inches)	Quantity
1-1/4, 1-1/2, 2, 2-1/2	2
1/2, 3/4	3

Table 21. Bottom Endwall

Knockout Size (Dimensions in Inches)	Quantity
1/2, 3/4	6
1/2, 3/4, 1, 1-1/4	2
1, 1-1/4, 1-1/2, 2, 2-1/2	1
1, 1-1/4, 1-1/2, 2, 2-1/2, 3	1

Dimensions and Knockouts (Non-EUSERC Meter Breaker Design) — Dimensions in Inches (mm)

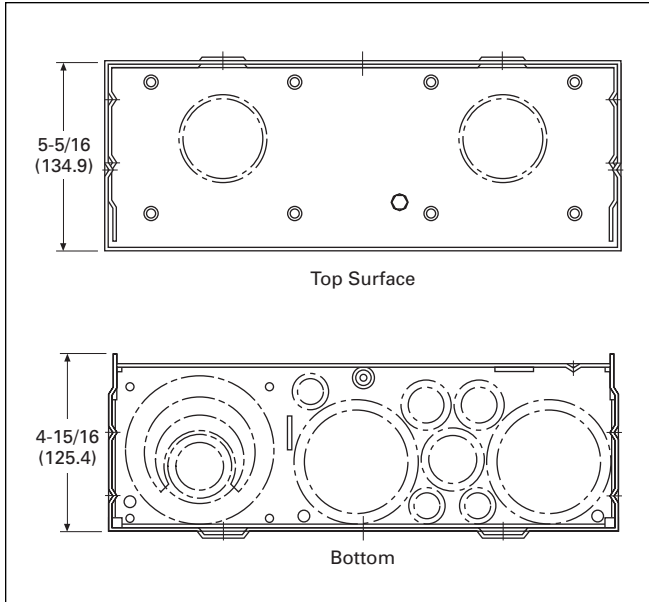

Figure 42. Knockouts for Non-EUSERC Units Catalog Numbers – MBB200BTS, MBP200BTS, MB816P200BTS, MB816P200BTSCU, MB816B200BTS, MB816B200BTSCU, MB2040P200BTS, MB2040B200BTS, MBP200SD, MB816P200STD and MB2040P200SD

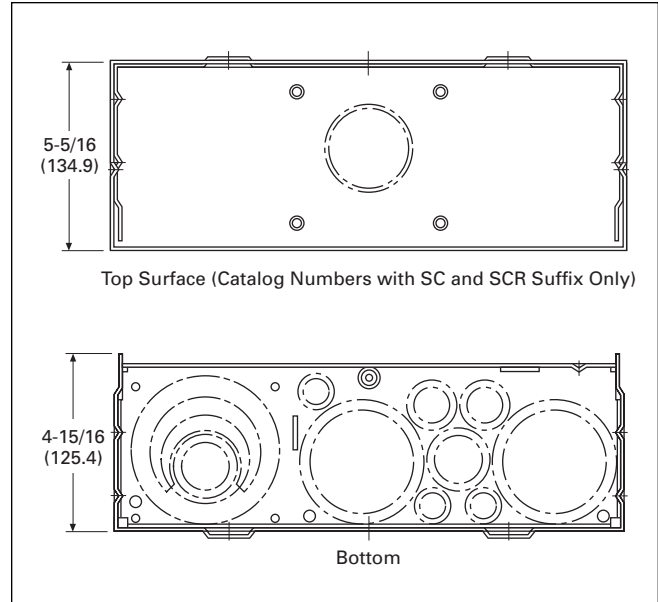

Figure 43. Knockouts for Non-EUSERC Units Catalog Numbers – MBB150BTSCR, MBB200BTSCR, MBP200BTSCR, MBB150BTSC and MBB200BTSC

Table 22. Top Endwall (Surface)

Hub Provision
DS100H2
DS125H2
DS150H2
DS200H2
DS250H2
DS300H2
DS900AP (Adapter Plate)

Table 23. Bottom Endwall

Knockout Size (Dimensions in Inches)	Quantity
5/16	3
1/2	3
1/2, 3/4	2
3/4, 1	1
1-1/4, 1-1/2, 2, 2-1/2	2
1-1/2, 2, 2-1/2, 3	1

Type CH Residential 300 Ampere and 400 Ampere "House Panels"



Type CH Residential — 300 Ampere and 400 Ampere "House Panels"

Product Description

A "House Panel" is a service entrance device that consists of a meter socket and a distribution section. The unit is rated at 300 amperes or 400 amperes.

Application Description

In addition to residential installations, a "house panel" could also be used for an apartment/condominium, clubhouse or common area. Verify local utility requirements before sale.

Features, Benefits and Functions

300 Ampere and 400 Ampere "House Panels"

- Underground feed only.
- "RH" type hub provisions on bottom endwall.
- Meets EUSERC requirements.
- Plug-on 400 ampere meter socket (320 ampere continuous).
- NEMA 3R — Rainproof.
- Lever bypass socket available on certain catalog numbers.
- Service entrance equipment and UL listed.
- Uses CH branch breakers.

Product Selection

Table 24. 300 – 400 Ampere "House Panels"

Ampere Rating	Security ①	Bypass	Main Breaker (Included)	Optional Main Breaker (Not Included)	Service Type	AIC	Distribution	Type CH Wiring Diagram	Line Side Main Lugs and Neutral	Catalog Number	
										Surface	Semi Flush ②
300	Ring	None ③	BW2200	CH	UG	10,000k	32/42	7	Landing studs for utility supplied compression lugs.	CG303242S	—
400	Ring	None ③	BW2200	CH	UG	10,000k	32/42	2		CG403242S	—
400	Ring	None ③	CSR2200N	CSR	UG	22,000k	32/42	2		CG403242SH	—
300	Ring	None ③	BW2200	CH	UG	10,000k	None	5		CG30S	—
400	Ring	None ③	BW2200	BW	UG	10,000k	None	4		CG40S	—
400	Ring	None ③	CSR2200N	CSR	UG	22,000k	None	4		CG40SH	—
300	Ringless	Lever	CSR2200N	CHB	UG	22,000/10,000k	42	3	CG304242SHL	—	
400	Ring	None	Provision	CSR	UG	22,000k	12	12	CG1212P400BS ④	—	
400	Ringless	Lever	CSR2200N	CSR	UG	22,000k	42	6	CG404242SHL	—	
300	Ringless	Lever	CSR2200N	CHB	UG	22,000k	None	1	CG30SHL	—	
400	Ringless	Lever	CSR2200N	CSR	UG	22,000/10,000k	None	4	CG40SHL	—	

① Confirm security type for individual EUSERC utility requirements.

② Semi Flush Flange kit — HPPR.

③ If manual bypass is needed, order bypass kit HPBPK.

④ Feed-through lugs included.

Technical Data and Specifications

Typical Wiring Diagrams (Type CH Style House Panels)

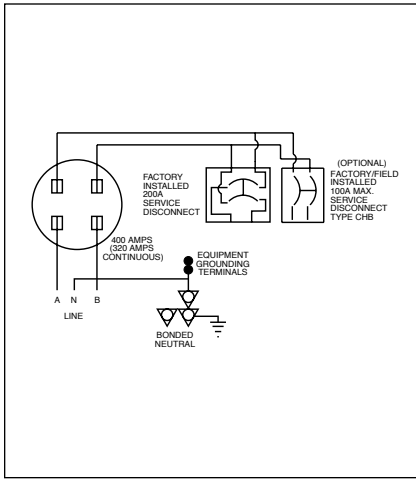

Figure 44. Type CH Wiring Diagram 1

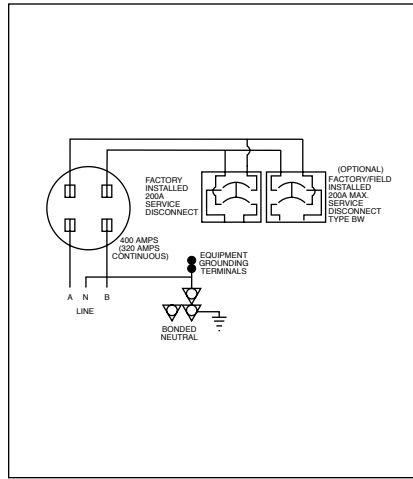

Figure 47. Type CH Wiring Diagram 4

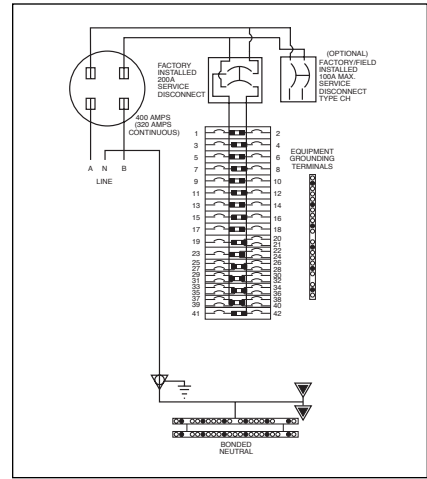

Figure 50. Type CH Wiring Diagram 7

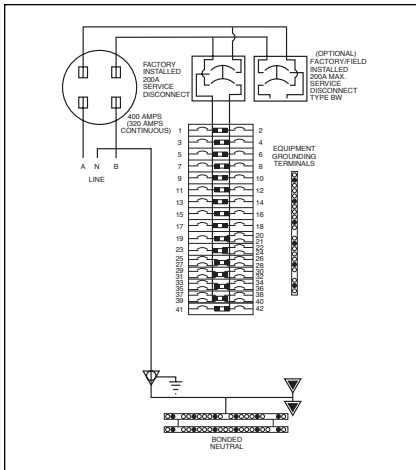

Figure 45. Type CH Wiring Diagram 2

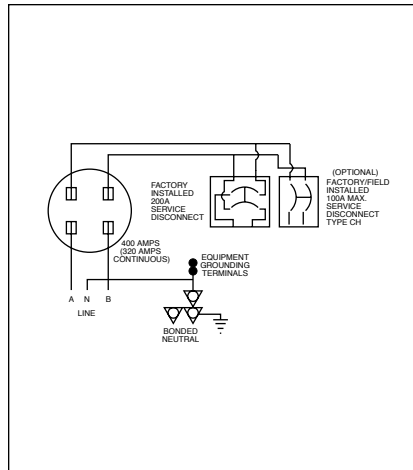

Figure 48. Type CH Wiring Diagram 5

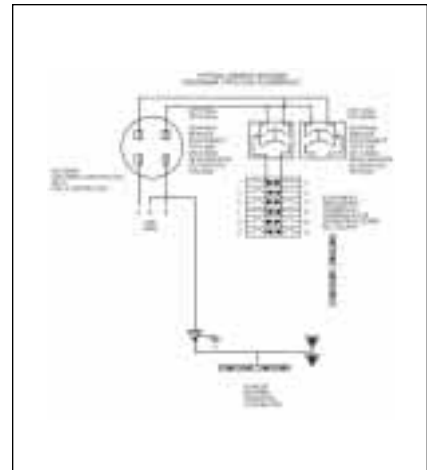

Figure 51. Type CH Wiring Diagram 8

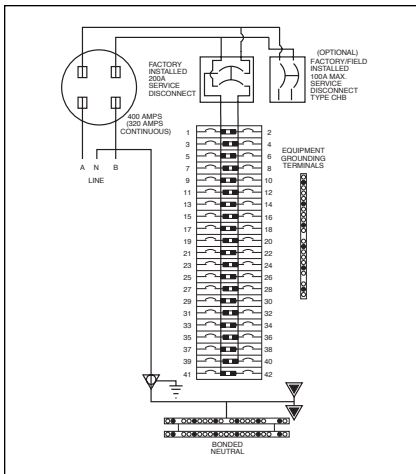

Figure 46. Type CH Wiring Diagram 3

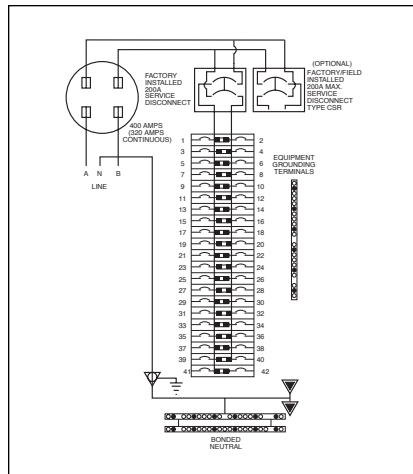

Figure 49. Type CH Wiring Diagram 6

Type CH Wiring Diagram Key

- #14-6 AWG
- #14-1/0 AWG
- ▽ #6 AWG - 250 kcmil
- ▽ #1 AWG - 300 kcmil

Dimensions and Knockouts (Type CH Style House Panels) — Dimensions in Inches

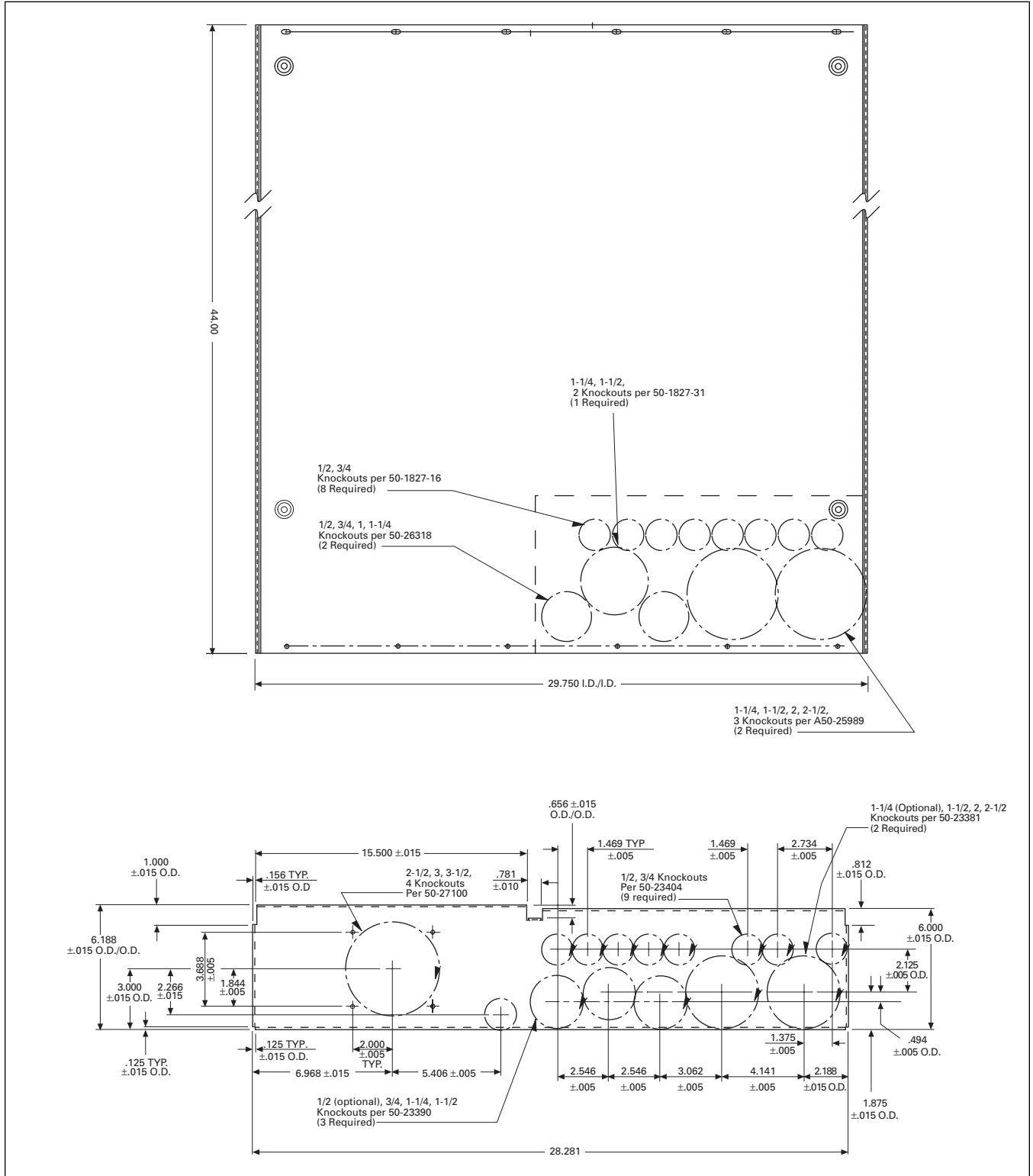

Figure 52. House Panel Dimensions and Knockouts

Type BR Residential 300 Ampere and 400 Ampere "House Panels"



Type BR Residential — 300 Ampere and 400 Ampere "House Panels"

Product Description

A "House Panel" is a service entrance device that consists of a meter socket and a distribution section. The unit is rated at 300 amperes or 400 amperes.

Application Description

In addition to residential installations, a "house panel" could also be used for an apartment/condominium, club-house or common area. Verify local utility requirements before sale.

Features, Benefits and Functions

300 Ampere and 400 Ampere "House Panels"

- Underground feed only.
- "RH" type hub provisions on bottom endwall.
- Meets EUSERC requirements.
- Plug-on 400 ampere meter socket (320 ampere continuous).
- NEMA 3R — Rainproof.
- Lever bypass socket available on certain catalog numbers.
- Service entrance equipment and UL listed.
- Uses BR branch breakers.

Product Selection

Table 25. 300 – 400 Ampere "House Panels"

Ampere Rating	Security ^①	Bypass	Main Breaker (Included)	Optional Secondary Main Breaker (Not Included)	Service Type	AIC	Distribution	Type BR Wiring Diagram	Line Side Main Lugs and Neutral	Catalog Number	
										Surface	Semi Flush ^②
400	Ring	None	DK2400	—	UG	22,000/10,000k	24/42	7	Landing studs for utility supplied compression lugs.	HP402442	—
300	Ring	None	BW2200	BR	UG	10,000k	24/40	9		HP304040S	—
300	Ring	None	BWH2200	BR	UG	22,000k	40	8		HP304040SH	—
400	Ring	None	BW2200	BW	UG	10,000k	24/40	4		HP402440S	—
400	Ring	None	BWH2200	BWH	UG	22,000/10,000k	24/40	4	Landing studs for utility supplied compression lugs.	HP404040SH	—
400	Ring	None	DK2400	—	UG	22,000/10,000k	None	1		HP40	—
300	Ring	None	BW2200	BR	UG	10,000k	None	2		HP30S	—
400	Ring	None	Provision	BW	UG	22,000/10,000k	8/16	11		HP816P400BS ^③	—
400	Ring	None	BW2200	BW	UG	10,000k	None	10		HP40S	—
400	Ringless	None	BWH2200	BWH	UG	22,000/10,000k	None	10		HP40SH	—
400	Ringless	None	DK2400	—	UG	22,000/10,000k	24/40	3		HP402440B ^④	—
400	Ringless	None	BW2200	BW	UG	10,000k	24/40	6		HP402440SB ^④	—
400	Ringless	None	BWH2200	BWH	UG	22,000/10,000k	24/40	6		HP402440SBH ^④	—
300	Ringless	Lever	BWH2200	BRH	UG	22,000/10,000k	None	2		HP30SHL	—
300	Ringless	Lever	BWH2200	BRH	UG	22,000/10,000k	40/40	5	HP304040SHL ^⑤	—	
400	Ringless	Lever	BWH2200	BWH	UG	22,000/10,000k	None	10		HP40SHL	—
400	Ringless	Lever	BWH2200	BWH	UG	22,000/10,000k	40/40	8		HP404040SHL ^⑤	—

① Confirm security type for individual EUSERC utility requirements.

② If unit needs to be semi-flush, order accessory item catalog number HPPR to convert all surface mounting devices to semi-flush mounting.

③ Feed-through lugs.

④ Bolt-on meter socket.

⑤ Secondary sub-main installed in panel.

Typical Wiring Diagrams (Type BR Style House Panels)

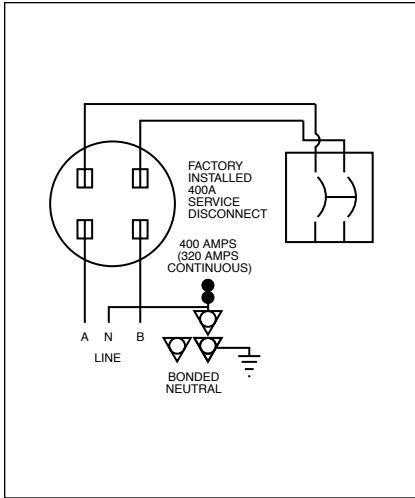

Figure 53. Type BR Wiring Diagram 1

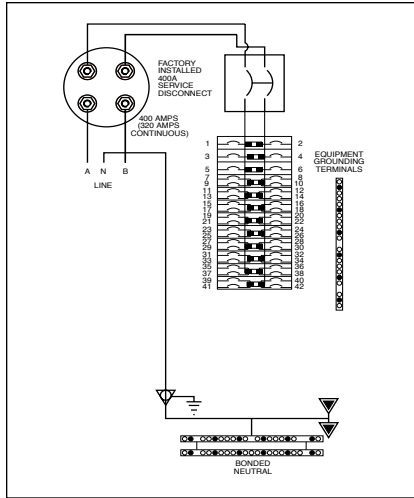

Figure 55. Type BR Wiring Diagram 3

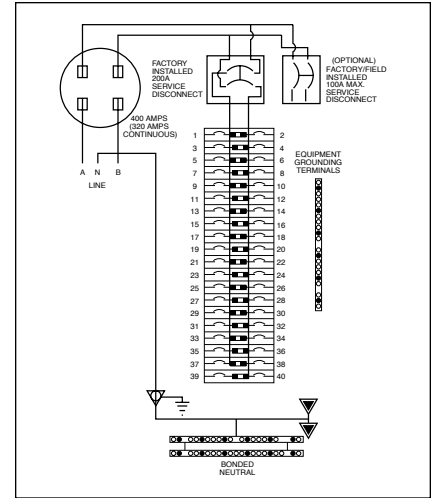

Figure 57. Type BR Wiring Diagram 5

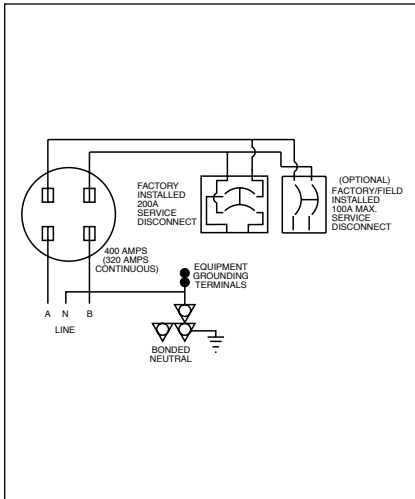

Figure 54. Type BR Wiring Diagram 2

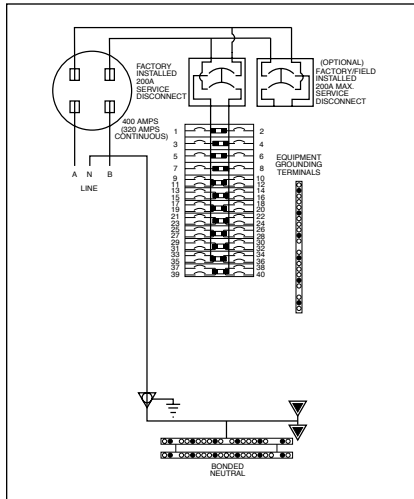

Figure 56. Type BR Wiring Diagram 4

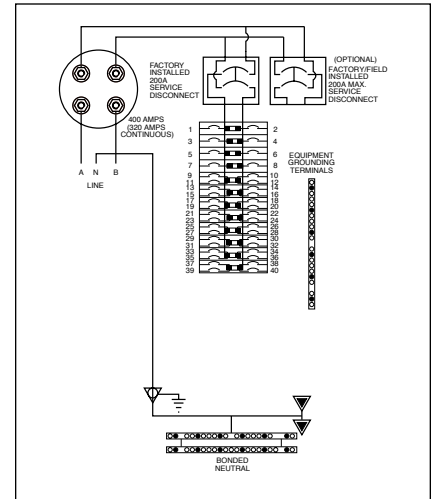

Figure 58. Type BR Wiring Diagram 6

Type BR Wiring Diagram Key

- #14-6 AWG
- #14-1/0 AWG
- ▽ #6 AWG - 250 kcmil
- ▽ #1 AWG - 300 kcmil

Typical Wiring Diagrams (Type BR Style House Panels)

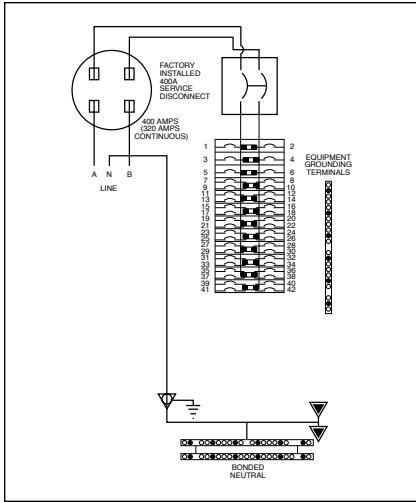

Figure 59. Type BR Wiring Diagram 7

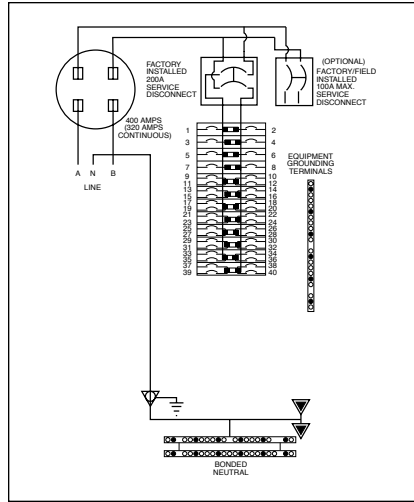

Figure 61. Type BR Wiring Diagram 9

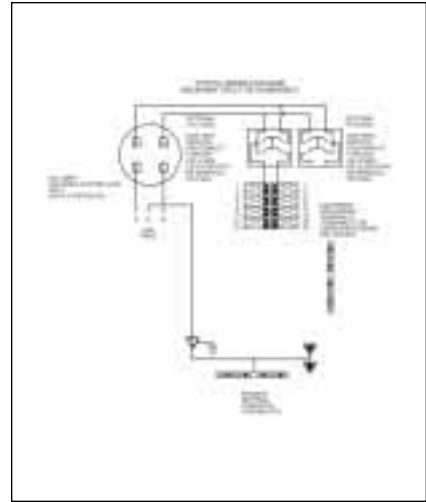

Figure 63. Type BR Wiring Diagram 11

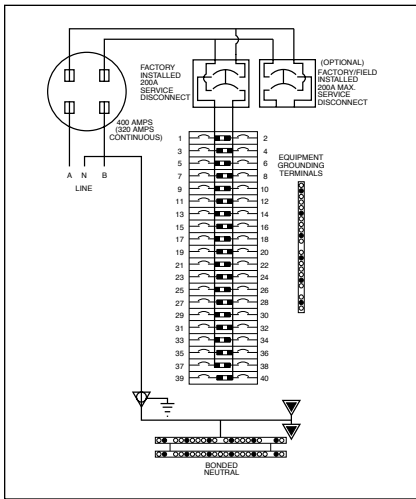

Figure 60. Type BR Wiring Diagram 8

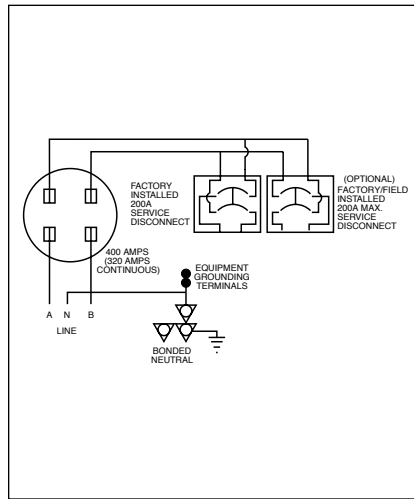

Figure 62. Type BR Wiring Diagram 10

Type BR Wiring Diagram Key

- #14-6 AWG
- #14-1/0 AWG
- ▽ #6 AWG - 250 kcmil
- ▽ #1 AWG - 300 kcmil

Dimensions and Knockouts (BR Style House Panels) — Dimensions in Inches

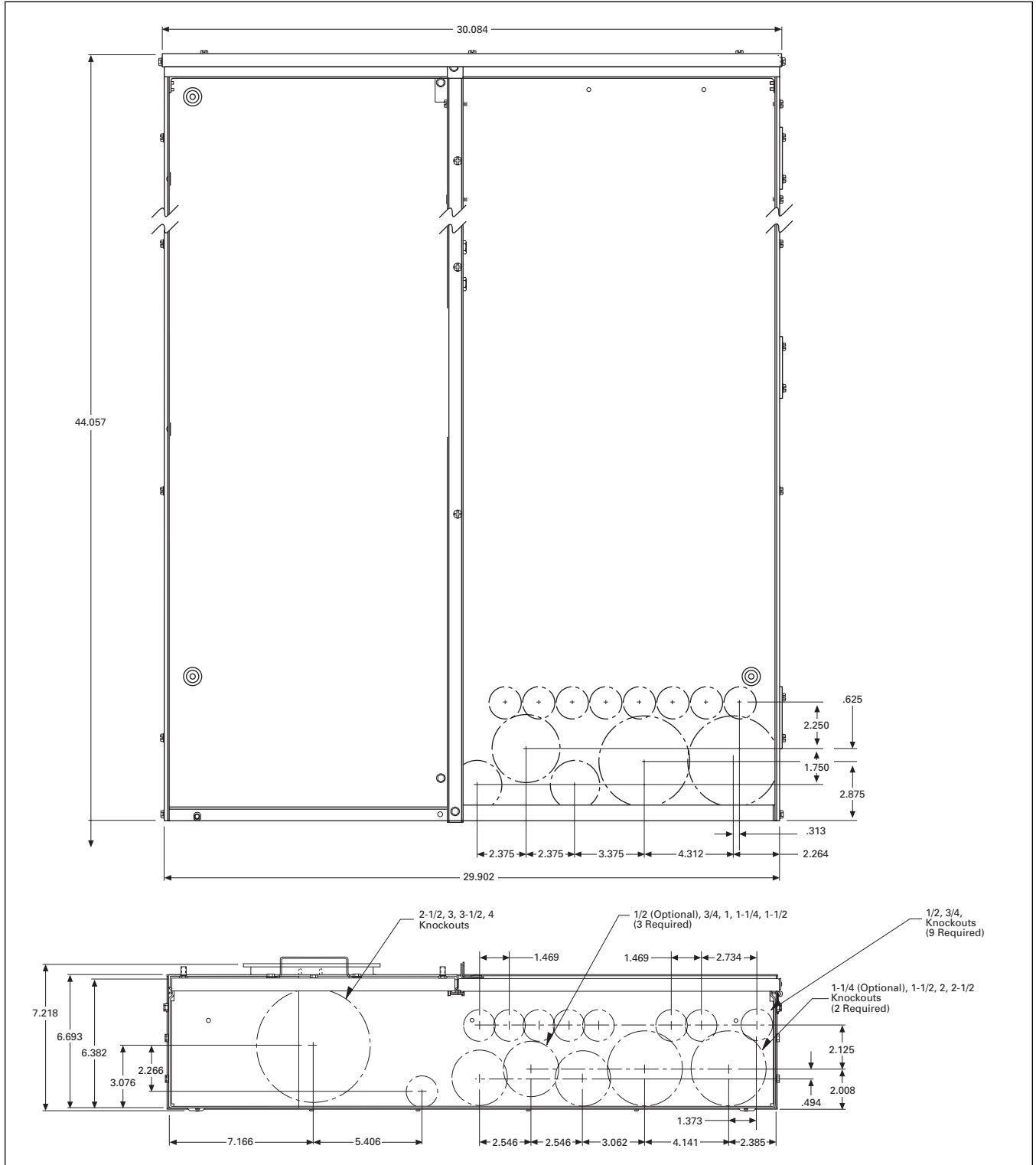

Figure 64. Type BR Meter Breaker Dimension Drawing 1

© 2001 Eaton Corporation, All Rights Reserved



New Information

Meter Breakers

Contents

<i>Description</i>	<i>Page</i>
Residential Meter Breakers	
Residential Meter Breakers	2
Product Selection	3, 4
Box Styles	5
Typical Wiring Diagrams	6 – 13
Dimensions and Knockouts	14 – 18
Type CH Residential 300 Ampere and 400 Ampere "House Panels"	
Product Selection	19
Typical CH Wiring Diagrams	20
Dimensions and Knockouts	21
Type BR Residential 300 Ampere and 400 Ampere "House Panels"	
Product Selection	22
Typical BR Wiring Diagrams	23, 24
Dimensions and Knockouts	25



Meter Breaker Family

Residential Meter Breakers



Residential Meter Breakers

Product Description

A meter breaker is service entrance equipment that consists of a single meter socket and loadcenter (circuit breaker distribution section) or meter socket and main breaker combined in one enclosure. Sometimes called Combos, All-In-Ones, Meter Centers or Meter Mains these units are increasing in popularity as the socket and load-center or main breaker are located in one location, thus providing the contractor with a labor and material savings when installing.

Application Description

In addition to residential installations, meter breakers are equally applicable for rural service entrance, mobile homes, and construction site temporary power. Meter breakers are most often sold in the Western, Southwestern and Southeastern United States. The popularity of meter breakers is continuing to increase as more utilities deregulate and pass the responsibility of supplying watt-hour meter sockets on to the electrical contractor.

Application Considerations

We have the meter breaker to meet your application. Cutler-Hammer offers:

- Non-EUSERC.
- EUSERC/West Coast (Electrical Utility Service Equipment Requirements Committee).
- House Panels.
- Commercial Safety Sockets.

Non-EUSERC

The Cutler-Hammer line of Non-EUSERC meter breakers is designed for customers served by utilities that are not members of EUSERC.

EUSERC/West Coast

The Cutler-Hammer line of EUSERC approved devices adheres to the agreed upon standards. EUSERC utilities are predominately located in the Western United States, but some Eastern and Midwestern utilities are also members. **These units can also be used in many Non-EUSERC areas.**

House Panels

Meter breaker device rated at 300 – 400A. Applied in EUSERC and Non-EUSERC areas.

Commercial Safety Sockets

Applied in EUSERC and Non-EUSERC service areas and used in commercial applications.

Standards and Certifications

- UL Specification 414.
- UL File Number E52977.
- AEIC-EEI-NEMA Standards (MSJ-7).
- Meet EUSERC Utility requirements where noted.
- Documented Seismic Qualified — UBC and CBC Title 24.

Product Specifications

- Ratings single-phase, 3-wire, 120/240V AC.
- 100 through 225 ampere main breaker and main lug types.
- 10,000 amperes rms symmetrical short circuit rating.

Features, Benefits and Functions

- Both BR and CH type branch circuit breaker styles available.
- Meets latest NEC wire bending space requirements.
- Slotted sealing screws at hub with sealing provision provided.
- Surface units are supplied with mounting tabs.
- Semi-flush units are supplied with stucco flange.
- Meter socket ring landing will accept locking security rings.
- Overhead or underground service.
- Fifth jaw can be installed in the 3 o'clock or 9 o'clock position.
- Semi-flush with nail flange or surface mounting.
- Meter mounting and underground pull sections are utility sealable.
- Units are rated a minimum of 10,000 AIC; some units are 22,000 AIC.
- Numerous units supplied with center keyhole for ease of mounting.

Product Selection

Table 1. Combination Service Entrance Devices (Non-EUSERC)

Ampere Rating	Bypass	Service	AIC	Jaws	Distribution	Main	Branch Breaker Type	Catalog Number	Box Dimension ①	Information Pages	
										Wiring	Knockout
Ring Style Meter Mains (no distribution section included)											
100	None	OH	Ⓣ	4	None	Provision ②	None	WMB102RN	8	N/A	N/A
150	None	OH/UG	10k	4	None	CSR2150	None	MBB150BTSCR ③	13	13	18
200	None	OH/UG	10k	4	None	CSR2200	None	MBB200BTSCR ③	13	13	18
200	None	OH/UG	Ⓣ	4	None	Provision ④⑤	None	MBP200BTSCR ③	13	13	18
200	None	OH/UG	22k	4	None	CSR2200	None	CMBB200BTS ⑥⑦	3	7	15

Ringless Meter Mains (no distribution section included)

150	None	OH/UG	10k	4	None	CSR2150	None	MBB150BTSC ⑥	13	13	18
200	None	OH/UG	10k	4	None	CSR2200	None	MBB200BTS	9	13	18
200	None	OH/UG	10k	4	None	CSR2200	None	MBB200BTSC ⑥	13	13	18
200	None	OH/UG	Ⓣ	4	None	Provision ④⑤	None	MBP200BTS	9	13	18
200	Horn	OH/UG	Ⓣ	5	None	Provision ④⑤	None	MBP200SD	11	13	18
200	Horn	OH/UG	Ⓣ	5	None	Provision ④⑤	None	MBP200BTSD	9	13	18

Ring Style All-In-Ones (includes distribution section)

125	None	OH/UG	Ⓣ	4	Will accept maximum four 1-pole, two 2-pole, or two quad breakers	None — Refer to Distribution	BR	WMB1224SCN WMB1224SCR ⑥	1	Refer to drawing 96-5500	—
125	None	OH/UG	Ⓣ	4		None — Refer to Distribution	BR		1		—
125	None	OH/UG	Ⓣ	4	2/4	None — Refer to Distribution	CH	CMB24L125BTS ⑥⑦	2	7	15
150	None	OH/UG	22k	4	8		CH		3	7	15
150	None	UG	22k	4	32/42	CSR2150	CH	CMB3242B150BS ⑥⑦	7	6	14
200	None	OH/UG	10k	4	4/8	BW2200	BR	MB48B200BTS ⑧⑨	3	9	15
200	None	OH/UG	22k	4	8	CSR2200	CH	CMB88B200BTS ⑧⑨⑦	3	7	15
200	None	UG	22k	4	32/42	CSR2200	CH	CMB3242B200BS ⑥⑦	7	6	14

Ringless All-In-Ones (includes distribution section)

200	None	OH/UG	10k	4	8/16	BW2200	BR	MB816B200BTS ⑧	10	13	18
200	None	OH/UG	10k	4	8/16	BW2200	BR	MB816B200BTSCU ⑦⑧	10	13	18
200	None	OH/UG	Ⓣ	4	8/16	Provision ④	BR	MB816P200BTS ⑧	10	13	18
200	None	OH/UG	Ⓣ	4	8/16	Provision ④	BR	MB816P200BTSCU ⑦⑧	10	13	18
200	Horn	OH/UG	Ⓣ	5	8/16	Provision ④	BR	MB816P200STD ⑧	11	13	18
200	Horn	OH/UG	Ⓣ	5	8/16	Provision ④	BR	MB816P200BTSD ⑧	10	13	18
200	Horn	OH/UG	Ⓣ	5	8/16	Provision ④	BR	MB816P200BTSCUD ⑦	10	13	18
200	None	OH/UG	10k	4	12/12	CSR2000	CH	CMB1212B200BTS ⑧⑦	10	11	16
200	Horn	OH/UG	22k	5	12/12	CSR2200	CH	CMB1212B200BTSD ⑧⑦	10	11	16
200	None	OH/UG	Ⓣ	4	6 – 2 Pole	Main Lugs	CH	CMB1212L200BTS ⑦	9	11	16
200	Horn	OH/UG	Ⓣ	5	6 – 2 Pole	Main Lugs	CH	CMB1212L200BTSD ⑦	9	11	16
200	None	OH/UG	Ⓣ	4	12/12	Provision ④	CH	CMB1212P200BTS ⑧⑦	10	11	16
200	Horn	OH/UG	Ⓣ	5	12/12	Provision ④	CH	CMB1212P200BTSD ⑧⑦	10	11	16
200	None	OH/UG	Ⓣ	4	6 – 2 Pole	Main Lugs	BR	MB1212L200BTS	9	11	16
200	None	OH/UG	22k	4	24/24	CSR2200	CH	CMB2424B200BTS	10	11	16
200	Horn	OH/UG	Ⓣ	5	6 – 2 Pole	Main Lugs	BR	MB1212L200BTSD	9	11	16
200	None	OH/UG	10k	4	20/40	BW2200	BR	MB2040B200BTS	10	13	18
200	None	OH/UG	Ⓣ	4	20/40	Provision ④	BR	MB2040P200BTS	10	13	18
200	Horn	OH/UG	Ⓣ	5	20/40	Provision ④	BR	MB2040P200SD	11	13	18
200	Horn	OH/UG	Ⓣ	5	20/40	Provision ④	BR	MB2040P200BTSD	10	13	18

① See Page 5 for box details.

② Provision for main is provided. WMB style devices accept Main Breaker style BR, 2-Pole.

③ Panels are specifically designed for the Georgia Power Service Territory, but may be used in any service territory that has the same design requirements.

④ When a provision for main is provided, order one of the main breakers listed in Table 2. All panels are dual labeled to accept Types BW or CSR Main Breakers.

⑤ MCBK225 lug kit is needed for load side cable connection for Meter Mains. Please order separately.

⑥ Single cover design.

⑦ Copper bus.

⑧ Units come with feed-through lugs.

⑨ One-piece cover on utility side Florida approved.

Ⓣ Per installed main breaker rating.

Table 2. Main Breaker Selection Chart

Maximum Ampere Rating	Catalog Number		
	10,000 AIC	22,000 AIC	
125	BW2125	BWH2125	CSR2125N
150	BW2150	BWH2150	CSR2150N
200	BW2200	BWH2200	CSR2200N
Load Side Lug Kit for BW and CSR Breakers. ⑩			MCBK225

⑩ When a provision for main is provided, order one of the main breakers listed in Table 2. All panels are dual labeled to accept Types BW or CSR Main Breakers.

Table 3. Combination Service Entrance Devices (EUSERC)

Ampere Rating	Bypass	Service	AIC	Jaws	Distribution	Main	Branch Breaker Type	Catalog Number		Box Dimension ①	Information Pages	
								Surface	Flush		Wiring	Knockout
Ring Style Meter Mains (no distribution section included)												
125	None	OH/UG	②	4	2/4	MLO	BR	MBE24L125BTS	MBE24L125BTF	2	9	15
125	None	OH/UG	②	4	2/4	MLO	CH	CMBE24L125BTS ⑤	CMBE24L125BTF ⑤	2	7	15
150	None	OH/UG	10k	4	None	BW2150	None	MBEB150BTS	MBEB150BTF	3	9	15
150	None	OH/UG	22k	4	None	CSR2150N	None	CMBEB150BTS ⑤	CMBEB150BTF ⑤	3	7	15
200	None	OH/UG	10k	4	None	BW2200	None	MBEB200BTS	MBEB200BTF	3	9	15
200	None	OH/UG	22k	4	None	CSR2200N	None	CMBEB200BTS ⑤	CMBEB200BTF ⑤	3	7	15
200	None	OH/UG	②	4	2/4	MLO	BR	MBE24L200BTS	MBE24L200BTF	3	9	15
200	None	OH/UG	②	4	2/4	MLO	CH	CMBE24L200BTS ⑤	CMBE24L200BTF ⑤	3	7	15
200	None	OH/UG	②	4	None	Provision	None	MBEP200BTS ⑥	N/A	3	9	15
Ring Style All-In-Ones (includes distribution section)												
100	None	OH/UG	10k	4	12/24	BR2100	BR	MBE1224B100BTS	MBE1224B100BTF	2	7	15
100	None	UG	10k	4	14/28	BR2100	BR	MBE1428B100BS	MBE1428B100BF	4	8	14
100	None	UG	10k	4	22	CH2100X	CH	CMBE2222B100BS ⑤	CMBE2222B100BF ⑤	5	6	14
100	None	OH	10k	4	12/24	BR2100	BR	MBE1224B100TS	MBE1224B100TF ③	9	13	16
125	None	OH/UG	10k	4	12/24	BR2125	BR	MBE1224B125BTS	MBE1224B125BTF	2	7	15
125	None	OH	10k	4	12/24	BR2125	BR	MBE1224B125TS	MBE1224B125TF ③	9	13	16
125	None	UG	10k	4	14/28	BR2125	BR	MBE1428B125BS	MBE1428B125BF	4	8	14
125	None	UG	10k	4	18/36	BR2125	BR	MBE1836B125BS	MBE1836B125BF	5	8	14
125	None	UG	10k	4	22	CH2125X	CH	CMBE2222B125BS ⑤	CMBE2222B125BF ⑤	5	6	14
150	None	OH/UG	22k	4	8	CSR2150N	CH	CMBE88B150BTS ④⑤	CMBE88B150BTF ④⑤	3	7	15
150	None	UG	22k	4	32/42	CSR2150N	CH	CMBE3242B150BS ⑤	CMBE3242B150BF ⑤	7	6	14
150	None	UG	10k	4	20/40	BW2150	BR	MBE2040B150BS	MBE2040B150BF	6	8	14
150	None	OH/UG	10k	4	4/8	BW2150	BR	MBE48B150BTS	MBE48B150BTF	3	9	15
150	None	OH/UG	10k	4	8	BW2150	BR	MBE88B150BTS	MBE88B150BTF	3	9	15
200	None	OH/UG	10k	4	4/8	BW2200	BR	MBE48B200BTS ④	MBE48B200BTF ④	3	9	15
200	None	OH/UG	22k	4	8	CSR2200N	CH	CMBE88B200BTS ④⑤	CMBE88B200BTF ④⑤	3	7	15
200	None	OH/UG	10k	4	8	BW2200	BR	MBE88B200BTS	MBE88B200BTF	3	9	15
200	None	OH/UG	②	4	8/16	Provision	BR	MBE816P200TSCU ⑤⑥	N/A	10	10	16
200	None	OH	②	4	8/16	Provision	BR	MBE816P200TS ④⑥	N/A	10	10	16
200	None	OH	②	4	6 – 2 Pole	Main Lug	CH	CMBE1212L200TS ⑤	N/A	9	10	16
200	None	UG	②	4	6 – 2 Pole	Main Lug	CH	CMBE1212L200BS ⑤	CMBE1212L200BF ⑤	5	6	14
200	None	OH	②	4	6 – 2 Pole	Main Lug	BR	MBE1212L200TS	N/A	9	10	16
200	None	UG	②	4	6 – 2 Pole	Main Lug	BR	MBE1212L200BS	MBE1212L200BF	5	8	14
200	None	OH	10k	4	20/40	BW2200	BR	MBE2040B200TS	MBE2040B200TF	10	10	16
200	None	UG	10k	4	20/40	BW2200	BR	MBE2040B200BS	MBE2040B200BF	6	8	14
200	None	OH	②	4	20/40	Provision	BR	MBE2040P200TS ⑥	MBE2040P200TF ③⑥	10	10	16
200	None	UG	22k	4	32/42	CSR2200N	CH	CMBE3242B200BS ⑤	CMBE3242B200BF ⑤	7	6	14
200	None	OH/UG	10k	4	40	BW2200	BR	MBE4040B200BTS	MBE4040B200BTF ③	12	12	17
200	None	OH/UG	22k	4	42	CSR2200N	CH	CMBE4242B200BTS ⑤	CMBE4242B200BTF ③⑤	12	12	17
200	None	OH/UG	10k	4	20/40	BW2200	BR	WMB202040S	WMB202040B	—	—	—
200	None	OH/UG	10k	4	4/8	BW2200	BR	WMB2048SLB ⑦	N/A	—	—	—
225	None	OH/UG	10k	4	20/40	BW2225	BR	WMB222040S	WMB222040F	—	—	—
225	None	UG	22k	4	32/42	CSR2225N	CH	CMBE3242B225BS ⑤	CMBE3242B225BF ⑤	7	6	14

- ① See Page 5 for box details.
- ② Interrupting rating is dependent on the main breaker that is installed.
- ③ Semi flush flange, not full stucco flange
- ④ Units come with feed-through lugs.
- ⑤ Unit has copper bus.
- ⑥ When a provision for main is provided, order one of the main breakers listed in Table 4. All panels are dual labeled to accept Types BW or CSR Main Breakers.
- ⑦ Use WMB70SMK if second main kit is needed.

Table 4. Main Breaker Selection Chart

Maximum Ampere Rating	Catalog Number		
	10,000 AIC	22,000 AIC	
125	BW2125	BWH2125	CSR2125N
150	BW2150	BWH2150	CSR2150N
200	BW2200	BWH2200	CSR2200N
Load Side Lug Kit for BW and CSR Breakers. ⑧			MCBK225

- ⑧ When a provision for main is provided, order one of the main breakers listed in Table 2. All panels are dual labeled to accept Types BW or CSR Main Breakers.

Box Styles

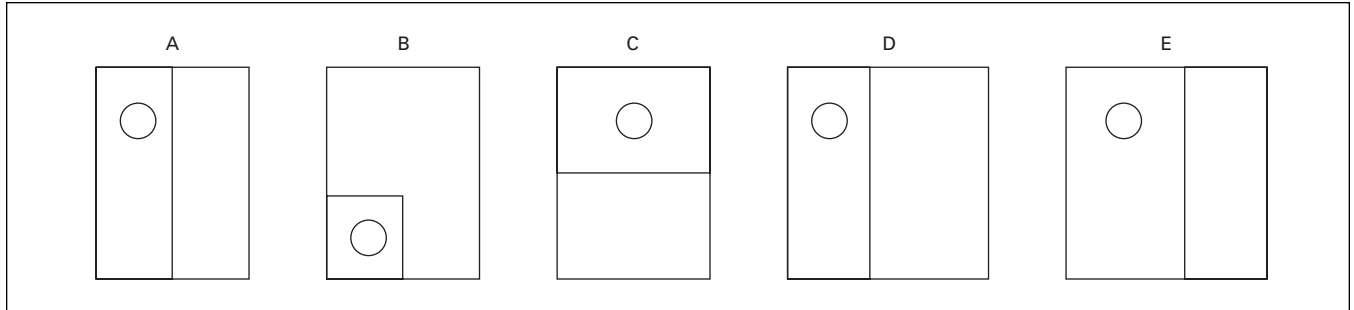

Figure 1. Five Different Styles (Shapes) of Product

Table 5. Box Dimensions

Box Number	Dimensions in Inches			Box Style
	Height	Width	Depth	
1	12-1/2 (317.5)	14-7/16 (366.7)	4 (101.6)	A
2	23-7/8 (606.4)	14-7/16 (366.7)	5-3/8 (136.5)	A
3	28-3/8 (720.7)	14-7/16 (366.7)	5-3/8 (136.5)	A
4	34-1/8 (866.8)	14-7/16 (366.7)	5-3/8 (136.5)	B
5	36-1/8 (917.6)	14-7/16 (366.7)	5-3/8 (136.5)	B
6	43-3/8 (1101.7)	14-7/16 (366.7)	5-3/8 (136.5)	B
7	46-7/8 (1190.6)	14-7/16 (366.7)	5-3/8 (136.5)	B
8	19-3/4 (501.7)	7-1/2 (190.5)	4 (101.6)	C
9	25-3/8 (644.5)	14-7/16 (366.7)	5-3/8 (136.5)	C
10	32-3/8 (822.3)	14-7/16 (366.7)	5-3/8 (136.5)	C
11	36-5/8 (930.3)	14-7/16 (366.7)	5-3/8 (136.5)	C
12	34-3/8 (873.1)	22 (558.8)	5-3/8 (136.5)	D
13	19-3/4 (501.7)	14-7/16 (366.7)	5-3/8 (136.5)	E

Table 6. Meter Breaker Parts

Description	Catalog Number
5th Jaw Kits	
Compact and Standard Styles (MB & CMB) WMB Style	1MM5JKOP WMB5J
Manual Bypass Kits	
Ring Style Units Only (MB)	1MMBPM200
Horn Bypass Kits	
Ringless Style Units Only (MB & CMB)	1MMBPH

Table 7. Wire Size Chart

Main	Wire Size Range Cu/Al 60°C or 75°C for Line Terminals
BR250 BR260 BR270	#14 – 4 kcmil #4 – 1/0 kcmil #4 – 1/0 kcmil
BR280 BR290 BR2100	#4 – 1/0 kcmil #4 – 1/0 kcmil #4 – 1/0 kcmil
BW2125 BW2150 BW2200	#2 – 300 kcmil #2 – 300 kcmil #2 – 300 kcmil
BWH2125 BWH2150 BWH2200	#2 – 300 kcmil #2 – 300 kcmil #2 – 300 kcmil
CSR2125N CSR2150N CSR2200N	#1/0 – 250 kcmil #1/0 – 250 kcmil #1/0 – 250 kcmil
125A Main Lugs 200A Main Lugs MCBK225	— — #2 – 300 kcmil

Table 8. Wire Size is Determined by the Circuit Breaker Installed in the Enclosure. Maximum Wire Size and Ampere Rating is Determined as Follows:

Wire/Application	Maximum	
	Wire Size	Ampere Rating
Aluminum — Standard	250 kcmil	200
Aluminum — Service Entrance	250 kcmil	225
Copper — Standard and Service Entrance	250 kcmil	225

Table 9. Hub Selection Chart

Hub Size Dimensions in Inches (mm)	Catalog Number
1 (25.4) 1-1/4 (31.8) 1-1/2 (38.1)	DS100H2 DS125H2 DS150H2
2 (50.8) 2-1/2 (63.5) 3 (76.2)	DS200H2 DS250H2 DS300H2

Typical Wiring Diagrams (Residential Meter Breakers)

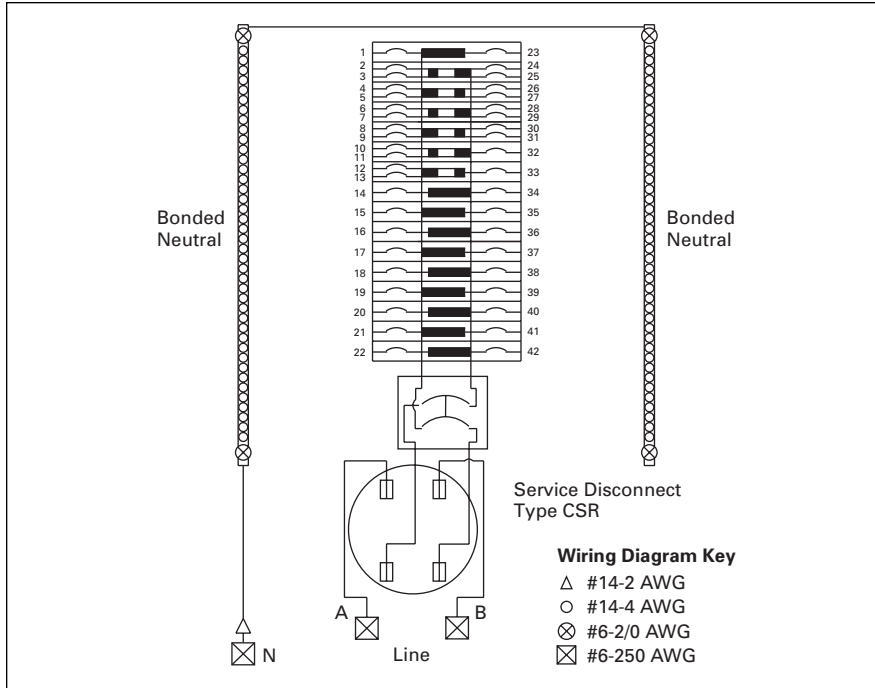

Figure 2. Catalog Numbers – CMB3242B200BS, CMBE3242B150BS, CMBE3242B150BF, CMBE3242B200BS, CMBE3242B200BF, CMBE3242B225BS, CMBE3242B225BF, CMB3242B150BS and CMB3242B200BS

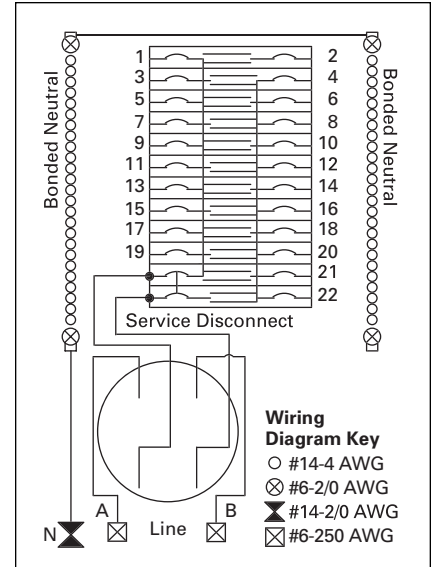

Figure 3. Catalog Numbers – CMBE2222B125BS, CMBE2222B125BF, CMBE2222B100BS and CMBE2222B100BF

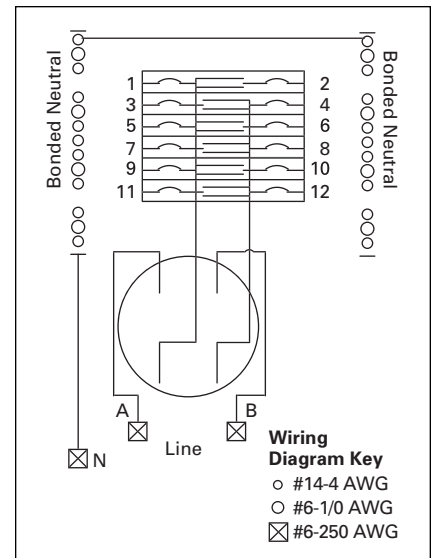

Figure 4. Catalog Numbers – CMBE1212L200BS and CMBE1212L200BF

Typical Wiring Diagrams (Residential Meter Breakers)

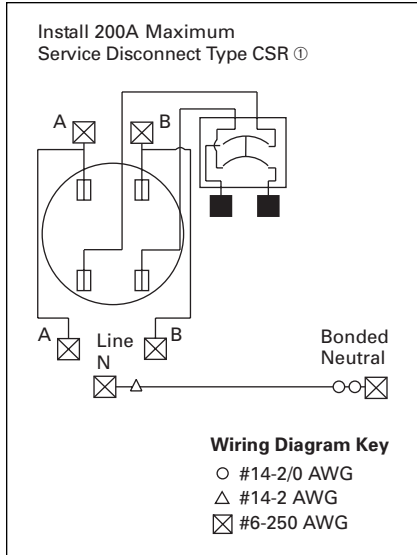

Figure 5. Catalog Numbers – CMBB200BTS, CMBEB150BTF, CMBEB150BTS, CMBEB200BTF and CMBEB200BTS

① Factory installed MCBK225 Kit for C/B load lugs.

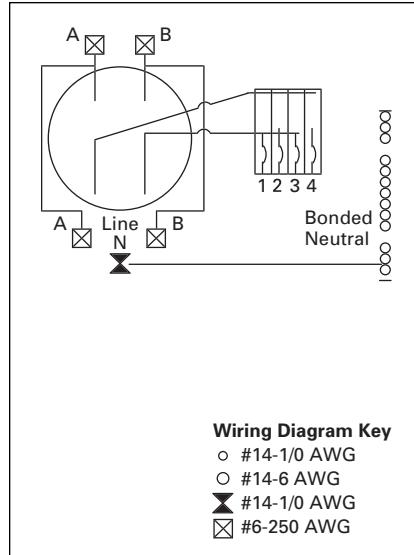

Figure 7. Catalog Numbers – CMBE24L125BTS, CMBE24L125BTF and CMB24L125BTS

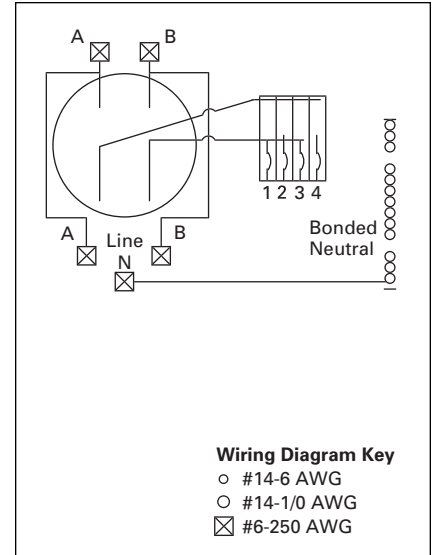

Figure 9. Catalog Numbers – CMBE24L200BTS and CMBE24L200BTF

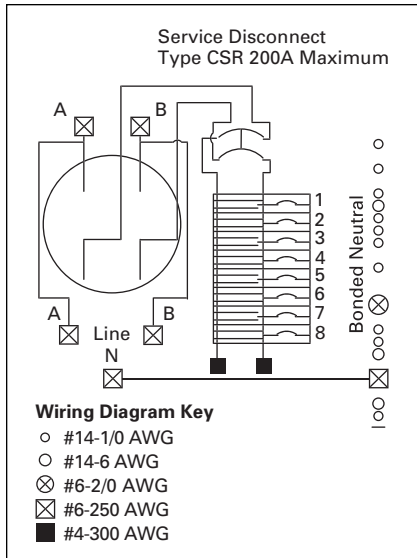

Figure 6. Catalog Numbers – CMBE88B200BTS, CMBE88B200BTF, CMB88B200BTS, CMB88B150BTS, CMBE88B150BTS and CMBE88B150BTF

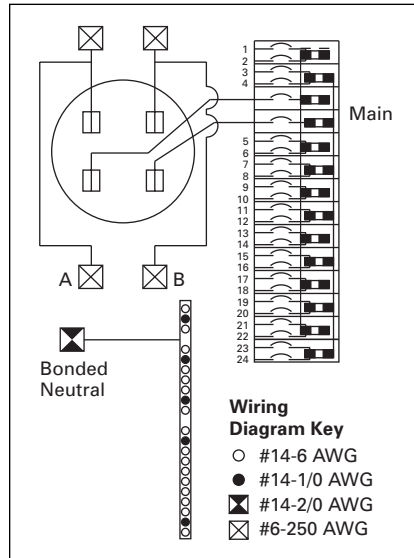

Figure 8. Catalog Numbers – MBE1224B100BTS, MBE1224B100BTF, MBE1224B125BTS and MBE1224B125BTF

Typical Wiring Diagrams (Residential Meter Breakers)

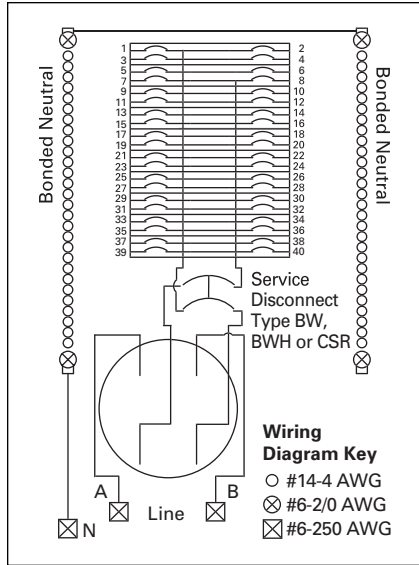

Figure 10. Catalog Numbers – MBE2040B150BS, MBE2040B150BF, MBE2040B200BS and MBE2040B200BF

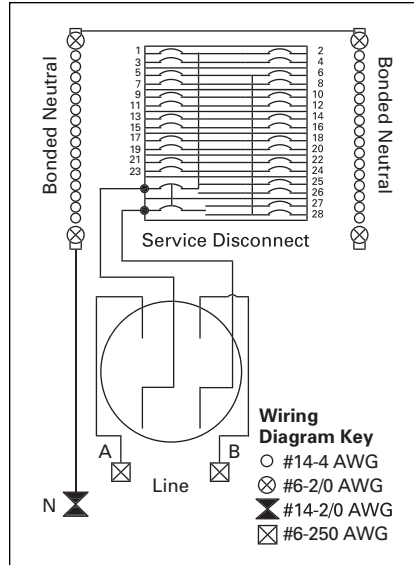

Figure 12. Catalog Numbers – MBE1428B100BS, MBE1428B100BF, MBE1428B125BS and MBE1428B125BF

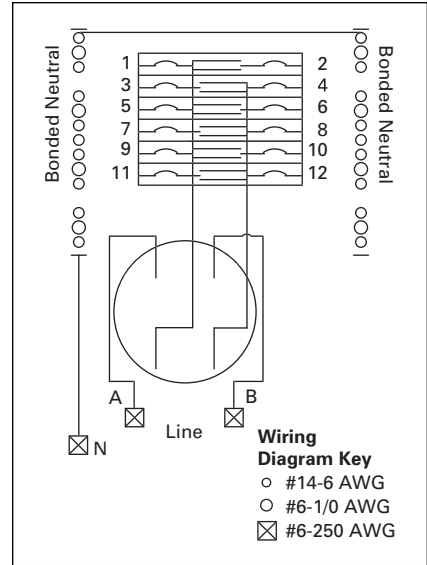

Figure 13. Catalog Numbers – MBE1212L200BS and MBE1212L200BF

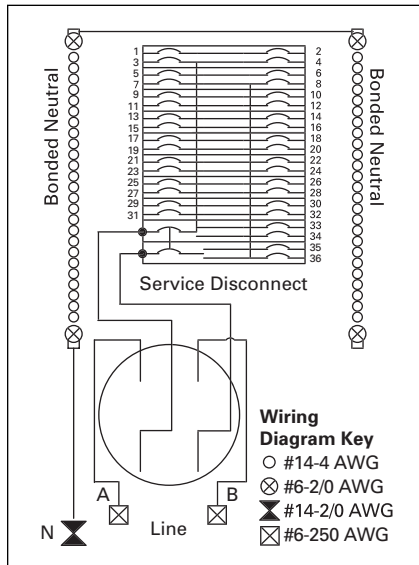

Figure 11. Catalog Numbers – MBE1836B125BS and MBE1836B125BF

Typical Wiring Diagrams (Residential Meter Breakers)

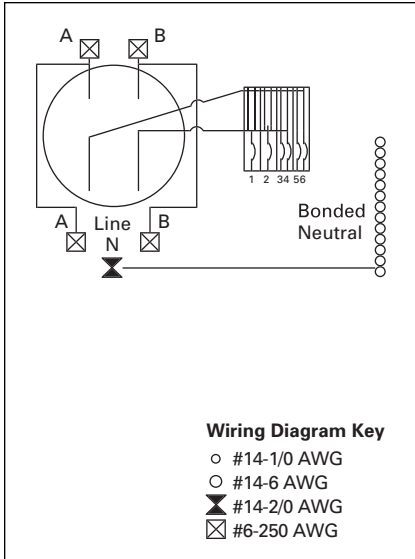

Figure 14. Catalog Numbers – MBE24L125BTS and MBE24L125BTF

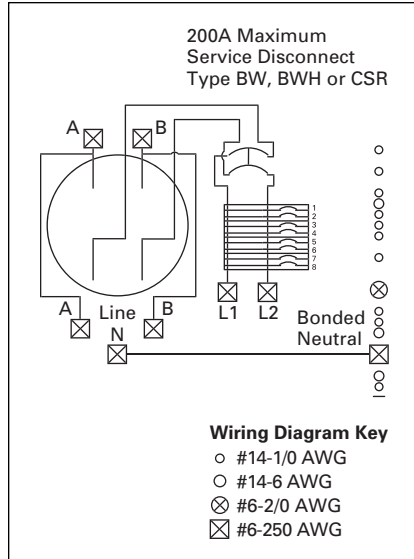

Figure 16. Catalog Numbers – MBE48B150BTS, MBE48B150BTF, MBE48B200BTS, MBE48B200BTF and MB48B200BTS

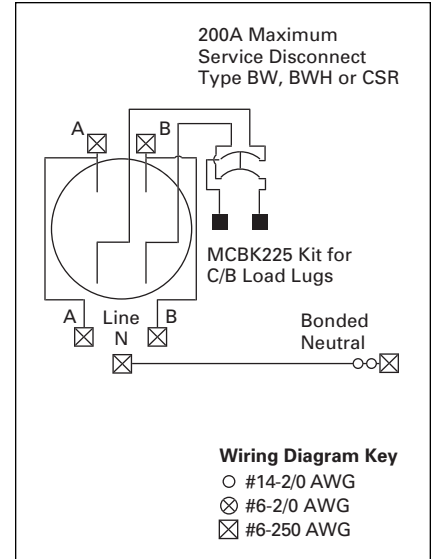

Figure 18. Catalog Numbers – MBEP200BTS, MBEB200BTS, MBEB200BTF, MBEB150BTS and MBEB150BTF

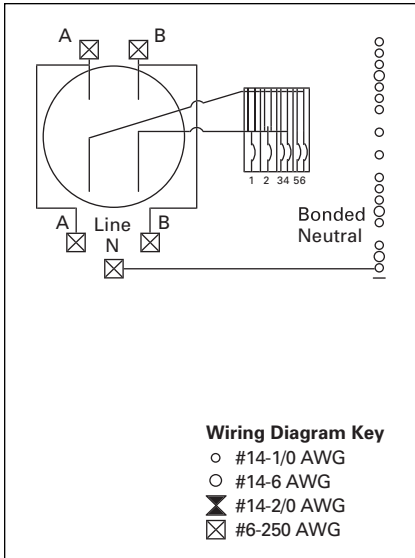

Figure 15. Catalog Numbers – MBE24L200BTS and MBE24L200BTF

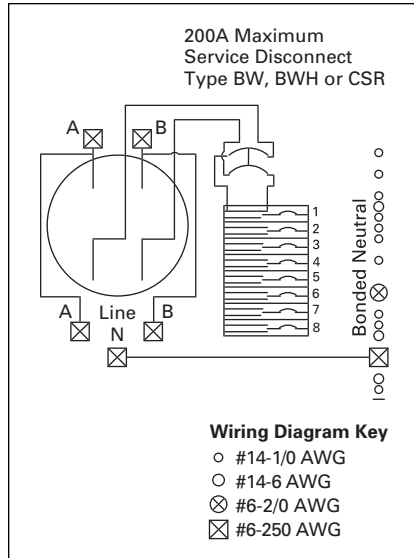

Figure 17. Catalog Numbers – MBE88B200BTS, MBE88B200BTF, MBE88B150BTS and MBE88B150BTF

Typical Wiring Diagrams (Residential Meter Breakers)

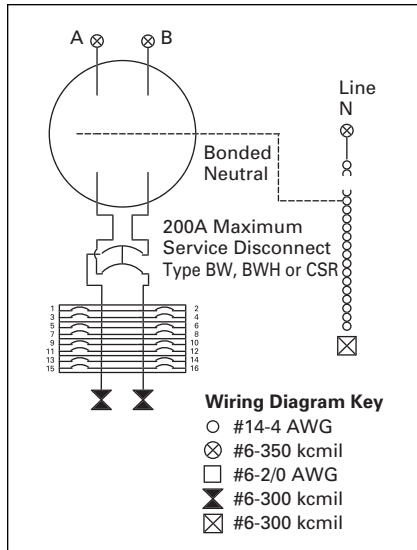

Figure 19. Catalog Numbers – MB816B200BTSCU, MBE816P200TS and MBE816P200TSCU

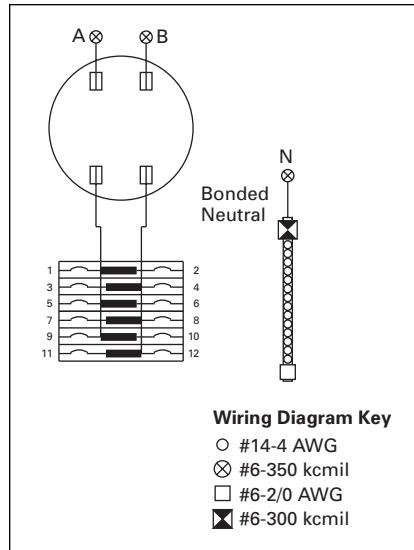

Figure 21. Catalog Number – MBE1212L200TS

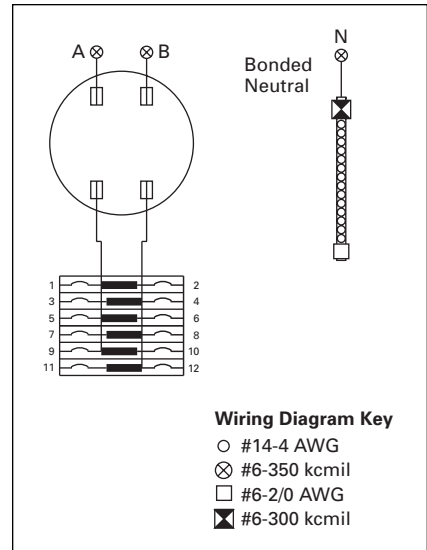

Figure 22. Catalog Number – CMBE1212L200TS

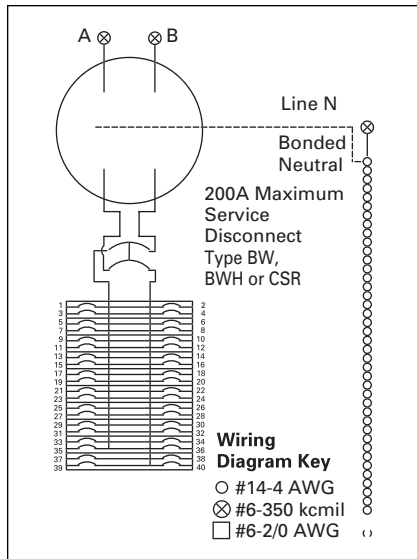

Figure 20. Catalog Numbers – MB2040P200BTSD, MBE2040P200TS, MBE2040P200TF, MBE2040B200TS, MBE2040B200TF

Typical Wiring Diagrams (Residential Meter Breakers)

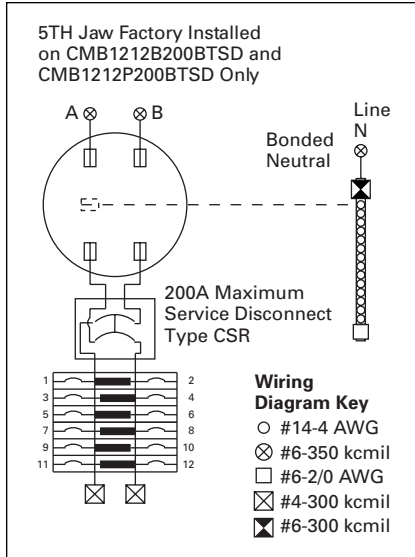

Figure 23. Catalog Numbers – CMB1212P200BTSD and CMB1212P200BTS

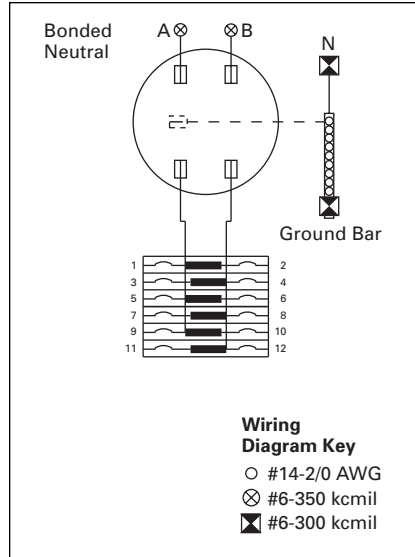

Figure 25. Catalog Numbers – MB1212L200BTS and MB1212L200BTSD

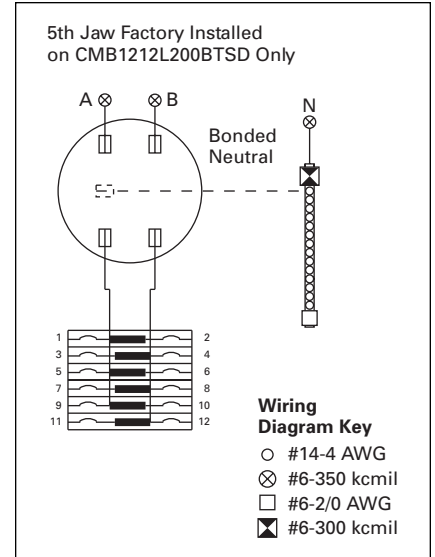

Figure 27. Catalog Numbers – CMB1212L200BTSD and CMB1212L200BTS

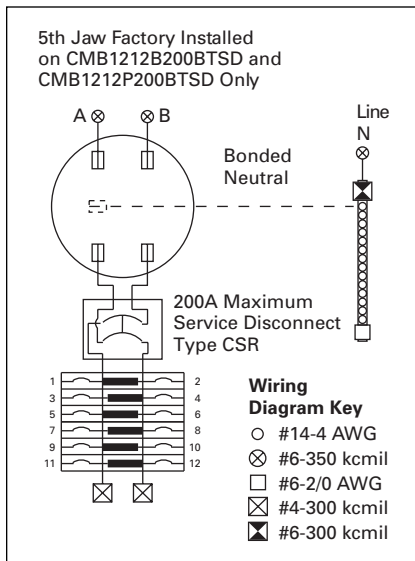

Figure 24. Catalog Numbers – CMB1212B200BTS and CMB1212B200BTSD

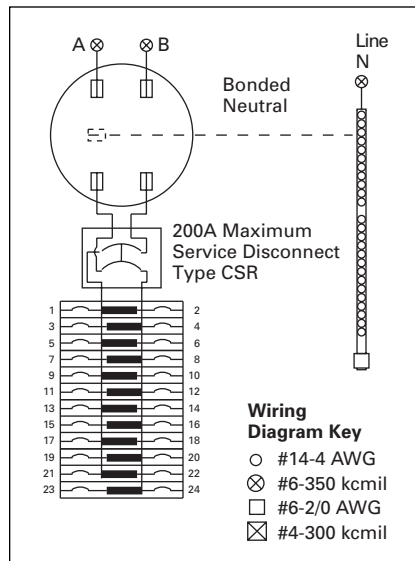

Figure 26. Catalog Numbers – CMB2424B200BTS

Typical Wiring Diagrams (Residential Meter Breakers)

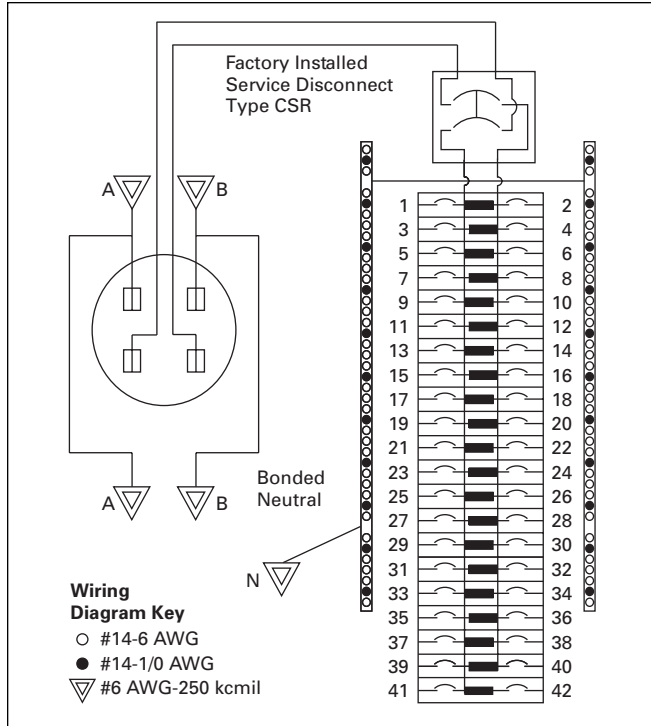

Figure 28. Catalog Numbers – CMBE4242B200BSH, CMBE4242B200BTS and CMBE4242B200BTF

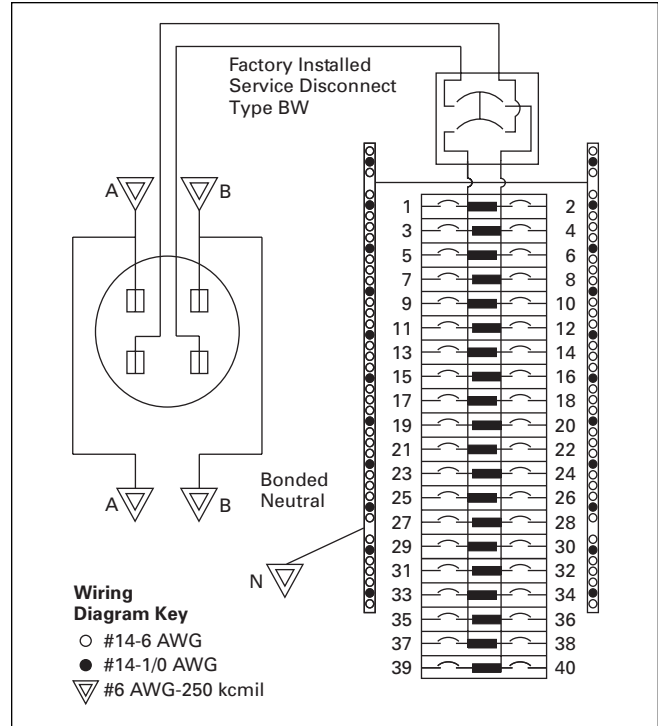

Figure 29. Catalog Numbers – MBE4040B200BTF, MBE4040B200BTS and MBE4040B200BSH

Typical Wiring Diagrams (Non-EUSERC Meter Breaker Design)

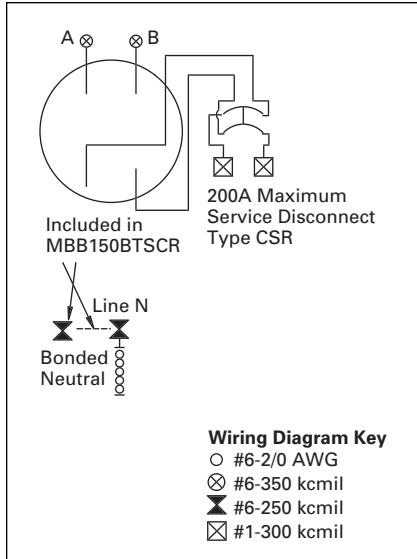

Figure 30. Catalog Numbers – MBB150BTSC, MBB150BTSCR, MBB200BTSCR, MBP200BTSCR and MBB200BTSC

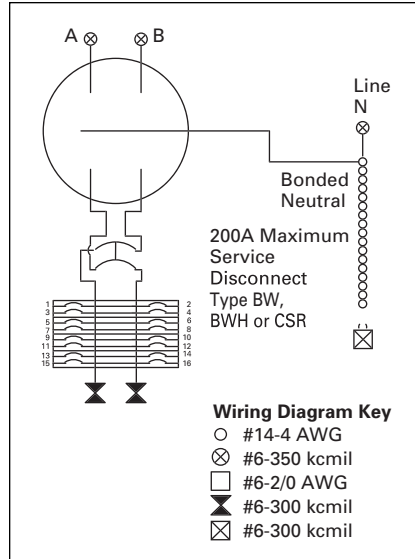

Figure 32. Catalog Numbers – MB816P200STD, MB816B200BTS, MB816B200BTSCU, MB816P200BTS, MB816P200BTSCU, MB816P200BTSD and MB816P200BTSCUD

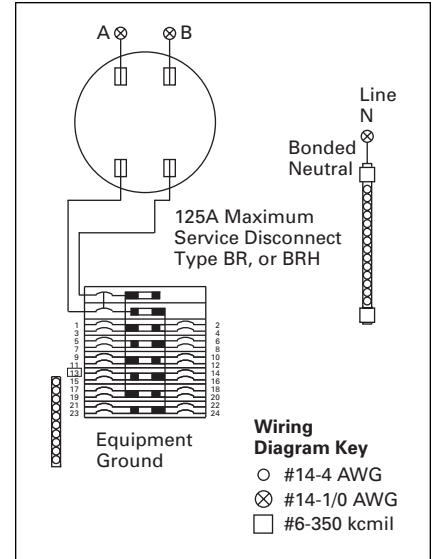

Figure 34. Catalog Numbers – MBE1224B125TS, MBE1224B125TF, MBE1224B100TS and MBE1224B100TF

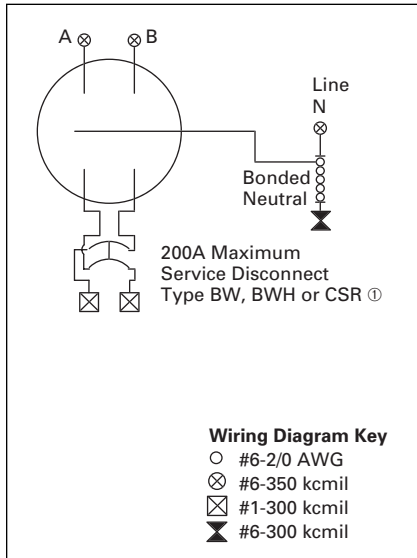

Figure 31. Catalog Numbers – MBP200SD, MBB200BTS, MBP200BTS and MBP200BTSD

① Use MCBK225 for C/B Load Lugs.

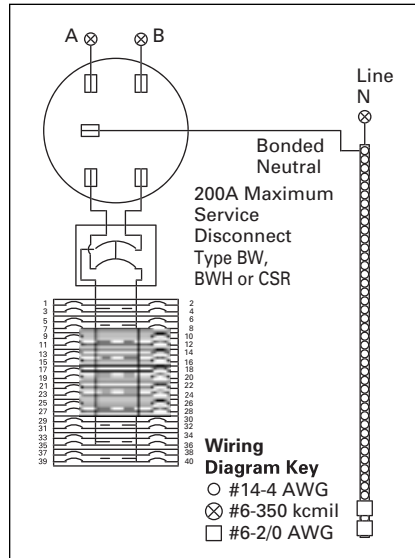

Figure 33. Catalog Numbers – MB2040P200SD, MB2040B200BTS, MB2040P200BTS and MB2040P200BTSD

Dimensions and Knockouts (Residential Meter Breakers) — Dimensions in Inches (mm)

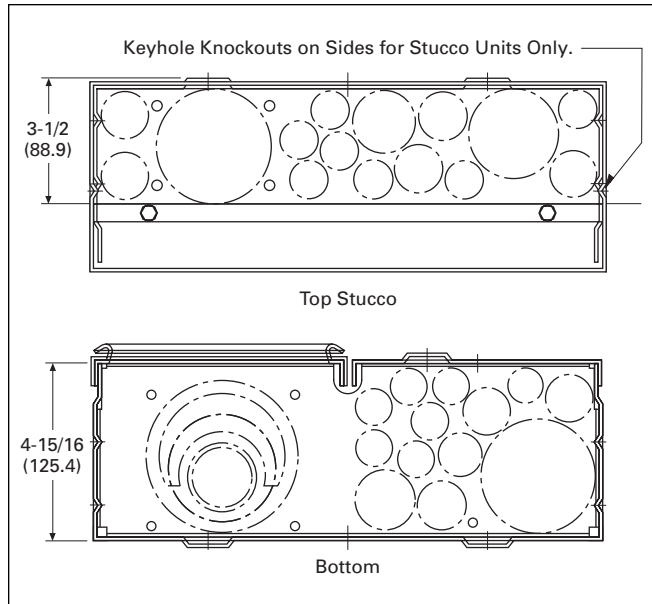

Figure 35. Knockouts for Stucco and Surface Units Catalog Numbers – CMBE3242B150BF, CMBE3242B200BF, CMBE3242B225BF, CMBE2222B100BF, CMBE2222B125BF, CMBE1212L200BF, MBE2040B200BF, MBE2040B150BF, MBE1428B100BF, MBE1428B125BF, MBE1212L200BF and MBE1836B125BF

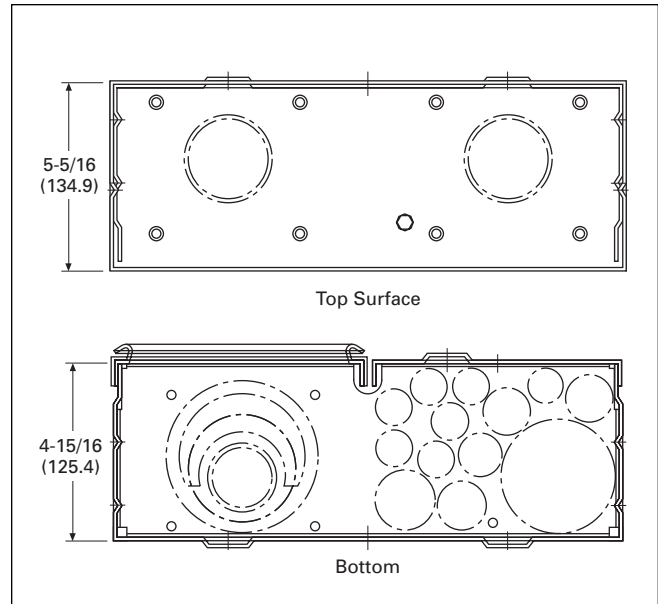

Figure 36. Knockouts for Stucco and Surface Units Catalog Numbers – CMBE3242B150BS, CMBE3242B200BS, CMBE3242B225BS, CMBE2222B100BS, CMBE2222B125BS, CMBE1212L200BS, MBE2040B200BS, MBE2040B150BS, MBE1428B100BS, MBE1428B125BS, MBE1212L200BS, MBE1836B125BS, CMB3242B150BS and CMB3242B200BS

Table 10. Top Endwall (Surface)

Hub Provision
DS100H2 DS125H2 DS150H2
DS200H2 DS250H2 DS300H2 DS900AP (Adapter Plate if using DS ___H1 hubs only) ①

① Use when DS H1 Type 1, 1-1/4 and 1-1/2-inch hubs are needed.

Table 11. Top Endwall (Stucco)

Knockout Size (Dimensions in Inches)	Quantity
1-1/4, 1-1/2, 2, 2-1/2	1
1, 1-1/4, 1-1/2	1
1/2, 3/4, 1	1
1/2, 3/4	5
1/2	7

Table 12. Bottom Endwall

Knockout Size (Dimensions in Inches)	Quantity
1/2,	7
1/2, 3/4	4
1/2, 3/4, 1	1
1, 1-1/4, 1-1/2, 2	1
1-1/4, 1-1/2, 2, 2-1/2, 3	1

Dimensions and Knockouts (Residential Meter Breakers) — Dimensions in Inches (mm)

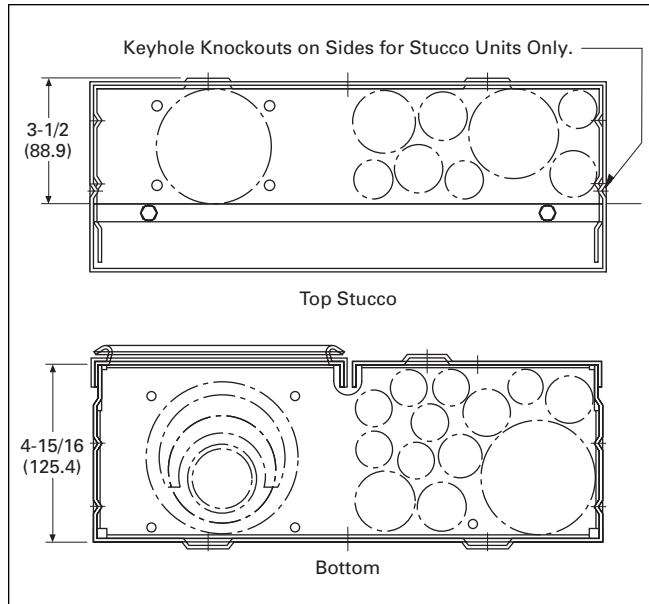

Figure 37. Knockouts for Stucco and Surface Units Catalog Numbers – CMBE24L200BTF, CMBE24L125BTF, CMBEB200BTF, CMBEB150BTF, CMBE88B150BTF, CMBE88B200BTF, MBE24L125BTF, MBE24L200BTF, MBE48B150BTF, MBE48B200BTF, MBE88B150BTF, MBE88B200BTF, MBEB150BTF, MBEB200BTF, MBE1224B100BTF and MBE1224B125BTF

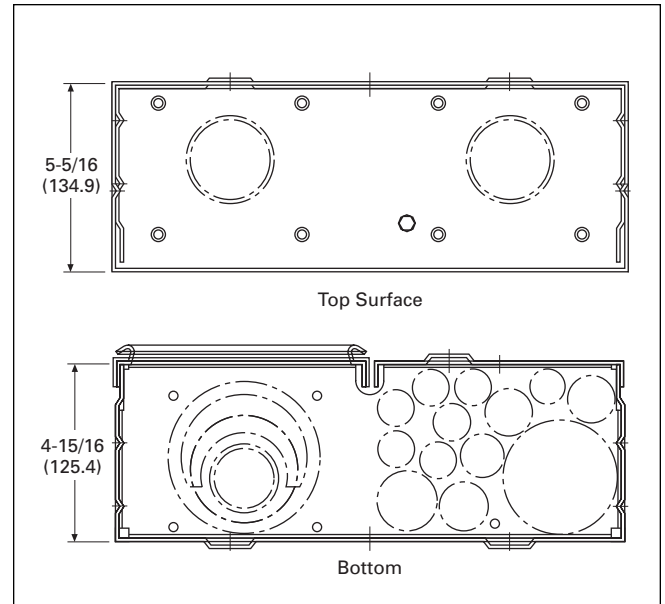

Figure 38. Knockouts for Stucco and Surface Units Catalog Numbers – CMBB200BTS, CMBE24L125BTS, CMB24L125BTS, CMBE24L200BTS, CMBEB200BTS, CMBEB150BTS, CMBE88B150BTS, CMBE88B200BTS, MBE24L125BTS, MBE24L200BTS, MBE48B150BTS, MBE48B200BTS, MBE88B150BTS, MBE88B200BTS, MBEB150BTS, MBEB200BTS, MBEP200BTS, MBE1224B100BTS, MBE1224B125BTS, CMB88B150BTS, CMB88B200BTS and MB48B200BTS

Table 13. Top Endwall (Surface)

Hub Provision
DS100H2 DS125H2 DS150H2
DS200H2 DS250H2 DS300H2 DS900AP (Adapter Plate) ①

① Use when DS H1 Type 1, 1-1/4 and 1-1/2-inch hubs are needed.

Table 14. Top Endwall (Stucco)

Knockout Size (Dimensions in Inches)	Quantity
1-1/4, 1-1/2, 2, 2-1/2	1
1, 1-1/4, 1-1/2	1
1/2, 3/4, 1	1
1/2, 3/4	3
1/2	3

Table 15. Bottom Endwall

Knockout Size (Dimensions in Inches)	Quantity
1/2	7
1/2, 3/4	4
1/2, 3/4, 1	1
1, 1-1/4, 1-1/2, 2	1
1-1/4, 1-1/2, 2, 2-1/2, 3	1

Dimensions and Knockouts (Residential Meter Breakers) — Dimensions in Inches (mm)

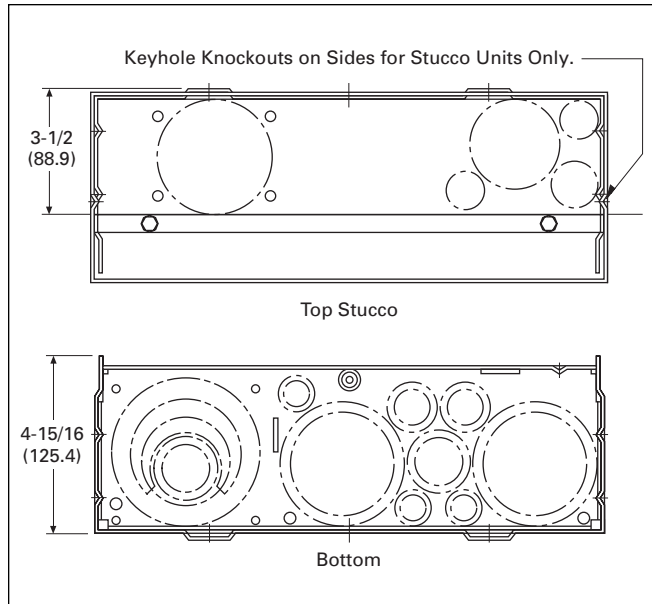

Figure 39. Knockouts for Stucco and Surface Units Catalog Numbers – MBE1224B100TF, MBE1224B125TF and MBE2040P200TF

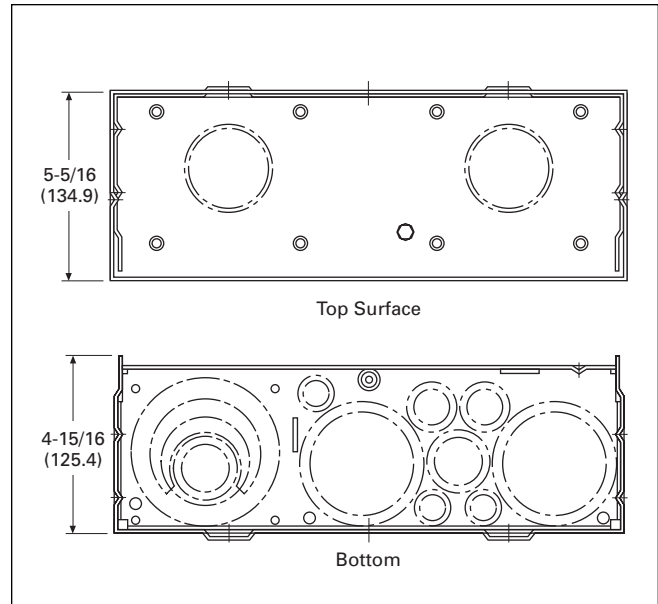

Figure 40. Knockouts for Stucco and Surface Units Catalog Numbers – MBE1224B100TS, MBE1224B125TS, MBE816P200TS, MBE816P200TSCU, MBE2040P200TS, MBE1212L200TS, CMBE1212L200TS, CMB1212P200BTS, CMB1212P200BTSD, CMB1212B200BTS, CMB1212B200BTSD, MB1212L200BTS, MB1212L200BTSD, CMB1212L200BTS and CMB1212L200BTSD

Table 16. Top Endwall (Surface)

Hub Provision
DS100H2 DS125H2 DS150H2
DS200H2 DS250H2 DS300H2 DS900AP (Adapter Plate) ①

① Use when DS H1 Type 1, 1-1/4 and 1-1/2-inch hubs are needed.

Table 17. Top Endwall (Stucco)

Knockout Size (Dimensions in Inches)	Quantity
1-1/4, 1-1/2, 2, 2-1/2	1
1, 1-1/4, 1-1/2	1
1/2, 3/4, 1	1
1/2, 3/4	5
1/2	7

Table 18. Bottom Endwall

Knockout Size (Dimensions in Inches)	Quantity
1/2	7
1/2, 3/4	4
1/2, 3/4, 1	1
1, 1-1/4, 1-1/2, 2	1
1-1/4, 1-1/2, 2, 2-1/2, 3	1

Dimensions and Knockouts (Residential Meter Breakers) — Dimensions in Inches (mm)

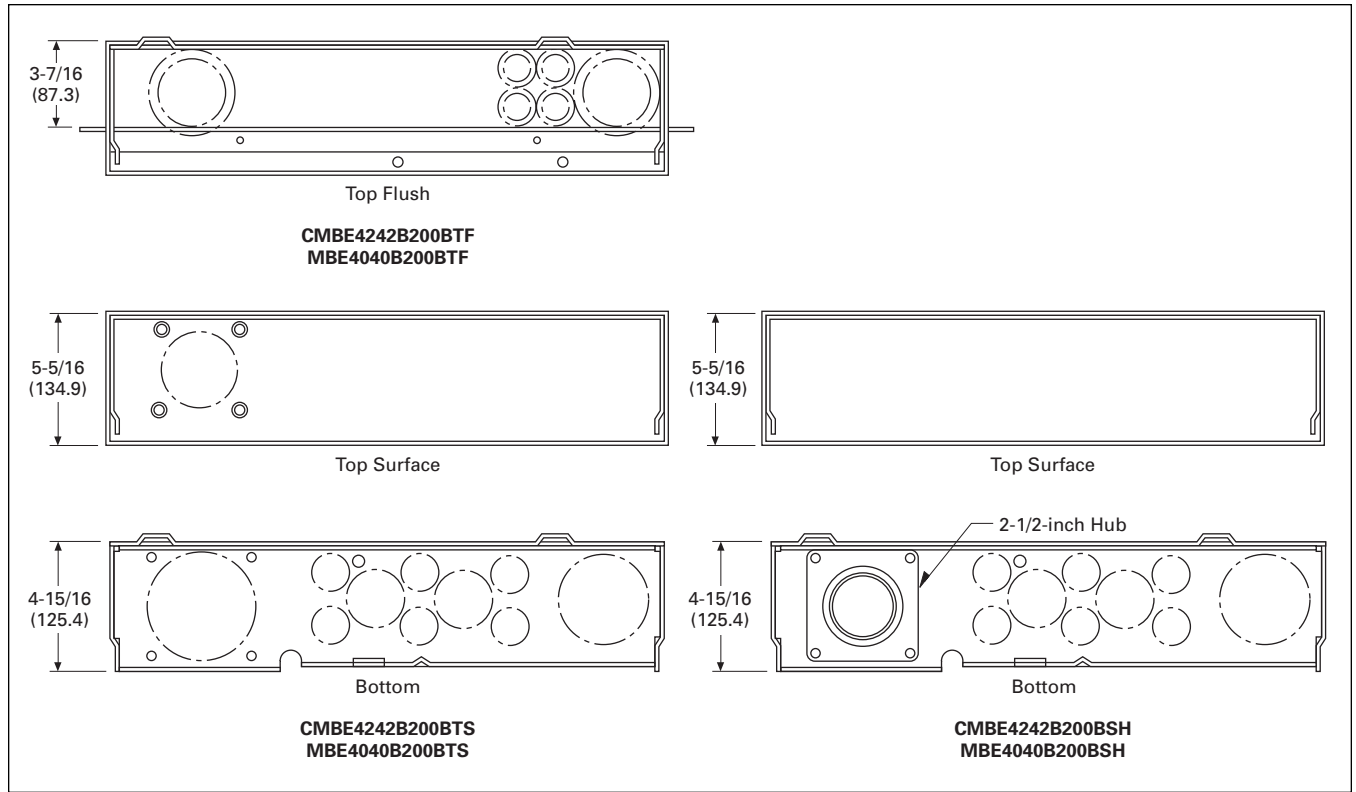

Figure 41. Knockouts for Stucco and Surface Units

Table 19. Top Endwall (Surface)

Hub Provision
DS100H2
DS125H2
DS150H2
DS200H2
DS250H2
DS300H2
DS900AP (Adapter Plate) ①

① Use when DS H1 Type 1, 1-1/4 and 1-1/2-inch hubs are needed.

Table 20. Top Endwall (Stucco)

Knockout Size (Dimensions in Inches)	Quantity
1-1/4, 1-1/2, 2, 2-1/2	2
1/2, 3/4	3

Table 21. Bottom Endwall

Knockout Size (Dimensions in Inches)	Quantity
1/2, 3/4	6
1/2, 3/4, 1, 1-1/4	2
1, 1-1/4, 1-1/2, 2, 2-1/2	1
1, 1-1/4, 1-1/2, 2, 2-1/2, 3	1

Dimensions and Knockouts (Non-EUSERC Meter Breaker Design) — Dimensions in Inches (mm)

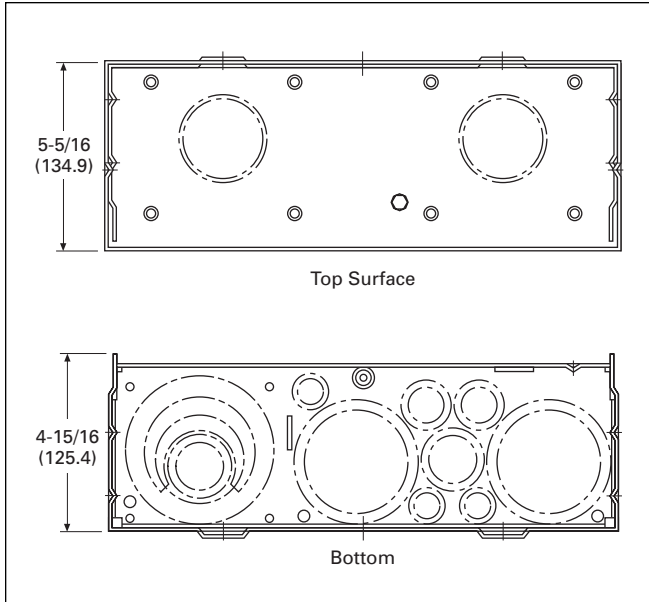

Figure 42. Knockouts for Non-EUSERC Units Catalog Numbers – MBB200BTS, MBP200BTS, MB816P200BTS, MB816P200BTSCU, MB816B200BTS, MB816B200BTSCU, MB2040P200BTS, MB2040B200BTS, MBP200SD, MB816P200STD and MB2040P200SD

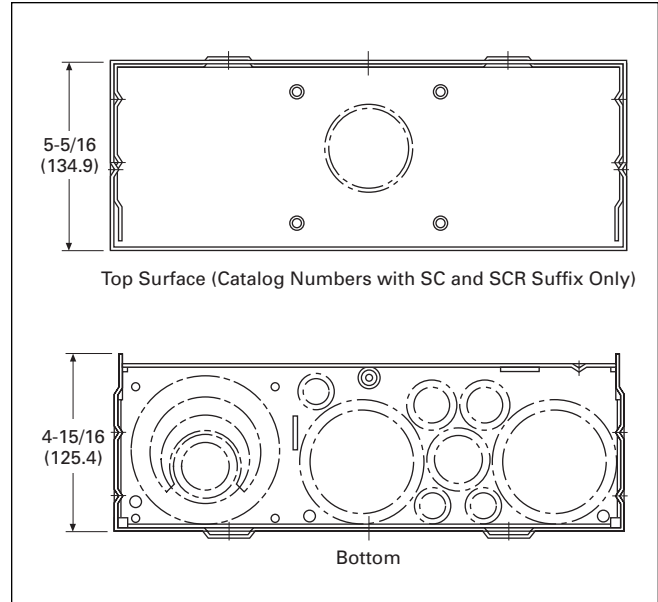

Figure 43. Knockouts for Non-EUSERC Units Catalog Numbers – MBB150BTSCR, MBB200BTSCR, MBP200BTSCR, MBB150BTSC and MBB200BTSC

Table 22. Top Endwall (Surface)

Hub Provision
DS100H2
DS125H2
DS150H2
DS200H2
DS250H2
DS300H2
DS900AP (Adapter Plate)

Table 23. Bottom Endwall

Knockout Size (Dimensions in Inches)	Quantity
5/16	3
1/2	3
1/2, 3/4	2
3/4, 1	1
1-1/4, 1-1/2, 2, 2-1/2	2
1-1/2, 2, 2-1/2, 3	1

**Type CH Residential
300 Ampere and 400 Ampere
“House Panels”**



*Type CH Residential — 300 Ampere
and 400 Ampere “House Panels”*

Product Description

A “House Panel” is a service entrance device that consists of a meter socket and a distribution section. The unit is rated at 300 amperes or 400 amperes.

Application Description

In addition to residential installations, a “house panel” could also be used for an apartment/condominium, clubhouse or common area. Verify local utility requirements before sale.

**Features, Benefits
and Functions**

**300 Ampere and 400 Ampere
“House Panels”**

- Underground feed only.
- “RH” type hub provisions on bottom endwall.
- Meets EUSERC requirements.
- Plug-on 400 ampere meter socket (320 ampere continuous).
- NEMA 3R — Rainproof.
- Lever bypass socket available on certain catalog numbers.
- Service entrance equipment and UL listed.
- Uses CH branch breakers.

Product Selection

Table 24. 300 – 400 Ampere “House Panels”

Ampere Rating	Security ①	Bypass	Main Breaker (Included)	Optional Main Breaker (Not Included)	Service Type	AIC	Distribution	Type CH Wiring Diagram	Line Side Main Lugs and Neutral	Catalog Number	
										Surface	Semi Flush ②
300	Ring	None ③	BW2200	CH	UG	10,000k	32/42	7	Landing studs for utility supplied compression lugs.	CG303242S	—
400	Ring	None ③	BW2200	CH	UG	10,000k	32/42	2		CG403242S	—
400	Ring	None ③	CSR2200N	CSR	UG	22,000k	32/42	2		CG403242SH	—
300	Ring	None ③	BW2200	CH	UG	10,000k	None	5		CG30S	—
400	Ring	None ③	BW2200	BW	UG	10,000k	None	4		CG40S	—
400	Ring	None ③	CSR2200N	CSR	UG	22,000k	None	4		CG40SH	—
300	Ringless	Lever	CSR2200N	CHB	UG	22,000/10,000k	42	3		CG304242SHL	—
400	Ring	None	Provision	CSR	UG	22,000k	12	12		CG1212P400BS ④	—
400	Ringless	Lever	CSR2200N	CSR	UG	22,000k	42	6		CG404242SHL	—
300	Ringless	Lever	CSR2200N	CHB	UG	22,000k	None	1	CG30SHL	—	
400	Ringless	Lever	CSR2200N	CSR	UG	22,000/10,000k	None	4	CG40SHL	—	

① Confirm security type for individual EUSERC utility requirements.

② Semi Flush Flange kit — HPPR.

③ If manual bypass is needed, order bypass kit HPBPK.

④ Feed-through lugs included.

Technical Data and Specifications

Typical Wiring Diagrams (Type CH Style House Panels)

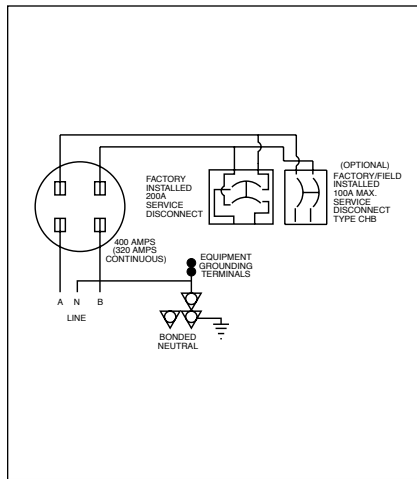

Figure 44. Type CH Wiring Diagram 1

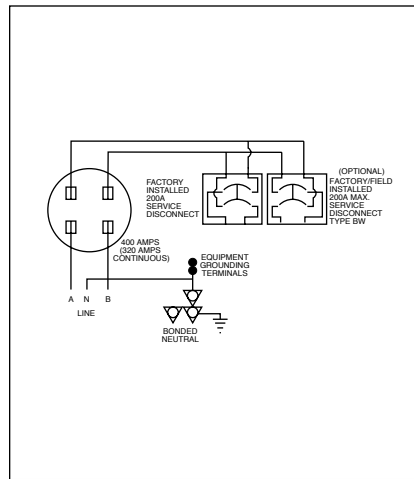

Figure 47. Type CH Wiring Diagram 4

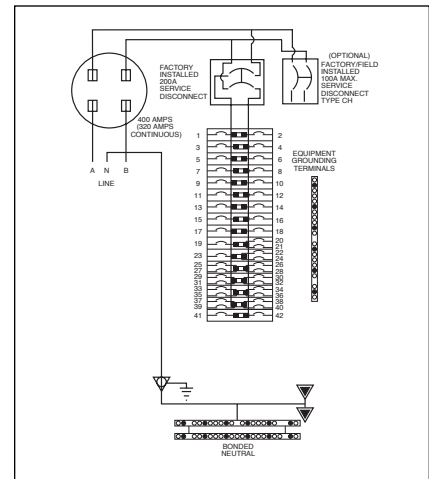

Figure 50. Type CH Wiring Diagram 7

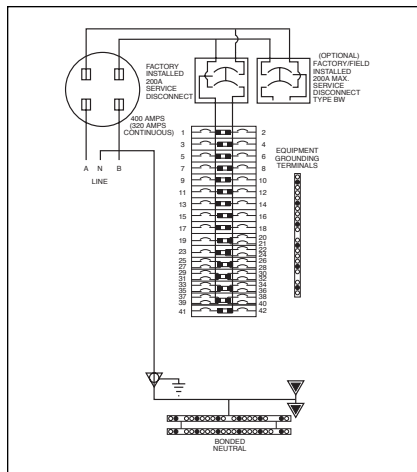

Figure 45. Type CH Wiring Diagram 2

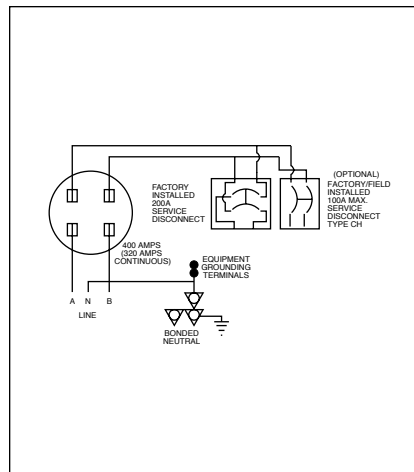

Figure 48. Type CH Wiring Diagram 5

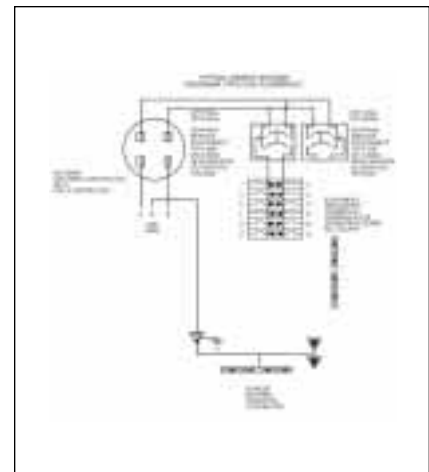

Figure 51. Type CH Wiring Diagram 8

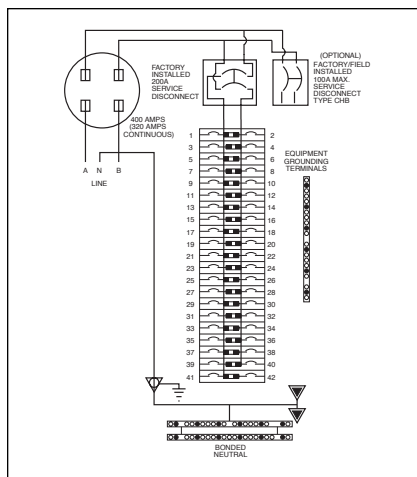

Figure 46. Type CH Wiring Diagram 3

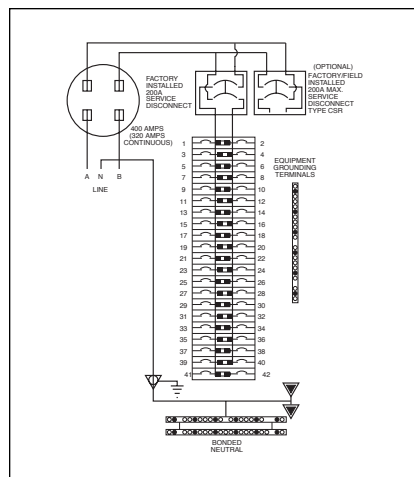

Figure 49. Type CH Wiring Diagram 6

Type CH Wiring Diagram Key

- #14-6 AWG
- #14-1/0 AWG
- ▽ #6 AWG - 250 kcmil
- ▽ #1 AWG - 300 kcmil

Dimensions and Knockouts (Type CH Style House Panels) — Dimensions in Inches

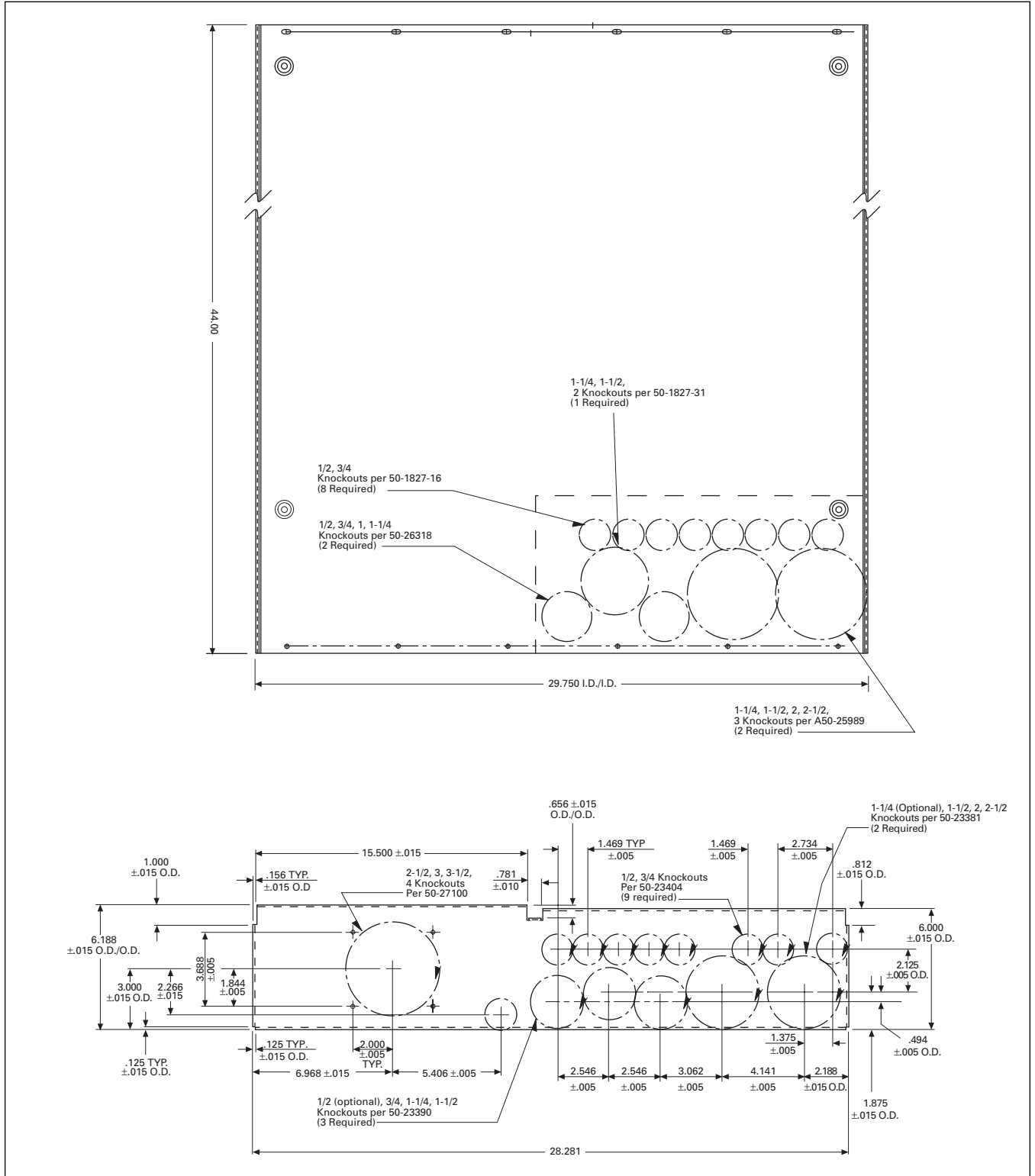

Figure 52. House Panel Dimensions and Knockouts

Type BR Residential 300 Ampere and 400 Ampere "House Panels"



Type BR Residential — 300 Ampere and 400 Ampere "House Panels"

Product Description

A "House Panel" is a service entrance device that consists of a meter socket and a distribution section. The unit is rated at 300 amperes or 400 amperes.

Application Description

In addition to residential installations, a "house panel" could also be used for an apartment/condominium, club-house or common area. Verify local utility requirements before sale.

Features, Benefits and Functions

300 Ampere and 400 Ampere "House Panels"

- Underground feed only.
- "RH" type hub provisions on bottom endwall.
- Meets EUSERC requirements.
- Plug-on 400 ampere meter socket (320 ampere continuous).
- NEMA 3R — Rainproof.
- Lever bypass socket available on certain catalog numbers.
- Service entrance equipment and UL listed.
- Uses BR branch breakers.

Product Selection

Table 25. 300 – 400 Ampere "House Panels"

Ampere Rating	Security ^①	Bypass	Main Breaker (Included)	Optional Secondary Main Breaker (Not Included)	Service Type	AIC	Distribution	Type BR Wiring Diagram	Line Side Main Lugs and Neutral	Catalog Number	
										Surface	Semi Flush ^②
400	Ring	None	DK2400	—	UG	22,000/10,000k	24/42	7	Landing studs for utility supplied compression lugs.	HP402442	—
300	Ring	None	BW2200	BR	UG	10,000k	24/40	9		HP304040S	—
300	Ring	None	BWH2200	BR	UG	22,000k	40	8		HP304040SH	—
400	Ring	None	BW2200	BW	UG	10,000k	24/40	4		HP402440S	—
400	Ring	None	BWH2200	BWH	UG	22,000/10,000k	24/40	4	Landing studs for utility supplied compression lugs.	HP404040SH	—
400	Ring	None	DK2400	—	UG	22,000/10,000k	None	1		HP40	—
300	Ring	None	BW2200	BR	UG	10,000k	None	2		HP30S	—
400	Ring	None	Provision	BW	UG	22,000/10,000k	8/16	11		HP816P400BS ^③	—
400	Ring	None	BW2200	BW	UG	10,000k	None	10		HP40S	—
400	Ringless	None	BWH2200	BWH	UG	22,000/10,000k	None	10		HP40SH	—
400	Ringless	None	DK2400	—	UG	22,000/10,000k	24/40	3		HP402440B ^④	—
400	Ringless	None	BW2200	BW	UG	10,000k	24/40	6		HP402440SB ^④	—
400	Ringless	None	BWH2200	BWH	UG	22,000/10,000k	24/40	6		HP402440SBH ^④	—
300	Ringless	Lever	BWH2200	BRH	UG	22,000/10,000k	None	2		HP30SHL	—
300	Ringless	Lever	BWH2200	BRH	UG	22,000/10,000k	40/40	5	HP304040SHL ^⑤	—	
400	Ringless	Lever	BWH2200	BWH	UG	22,000/10,000k	None	10		HP40SHL	—
400	Ringless	Lever	BWH2200	BWH	UG	22,000/10,000k	40/40	8		HP404040SHL ^⑤	—

① Confirm security type for individual EUSERC utility requirements.

② If unit needs to be semi-flush, order accessory item catalog number HPPR to convert all surface mounting devices to semi-flush mounting.

③ Feed-through lugs.

④ Bolt-on meter socket.

⑤ Secondary sub-main installed in panel.

Typical Wiring Diagrams (Type BR Style House Panels)

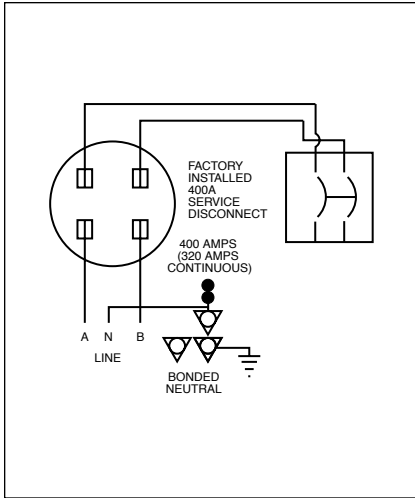

Figure 53. Type BR Wiring Diagram 1

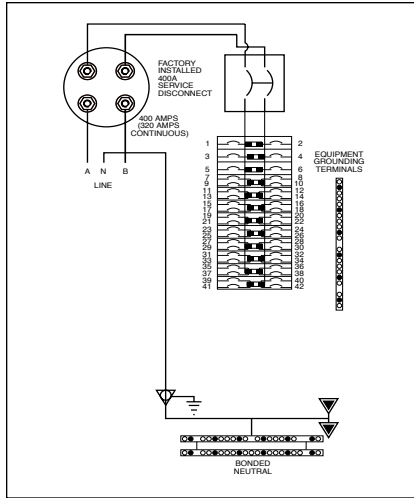

Figure 55. Type BR Wiring Diagram 3

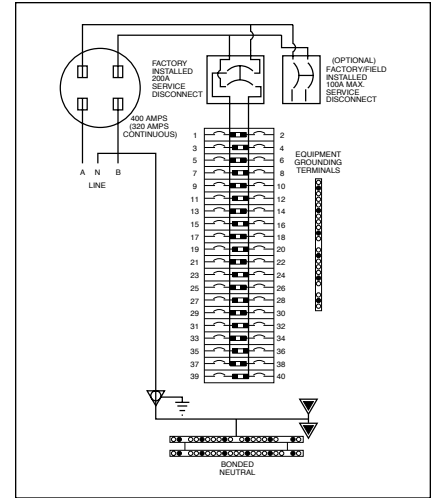

Figure 57. Type BR Wiring Diagram 5

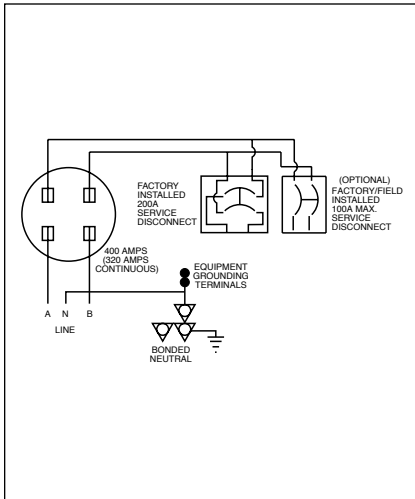

Figure 54. Type BR Wiring Diagram 2

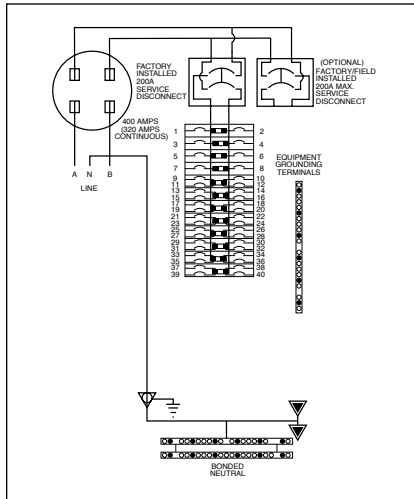

Figure 56. Type BR Wiring Diagram 4

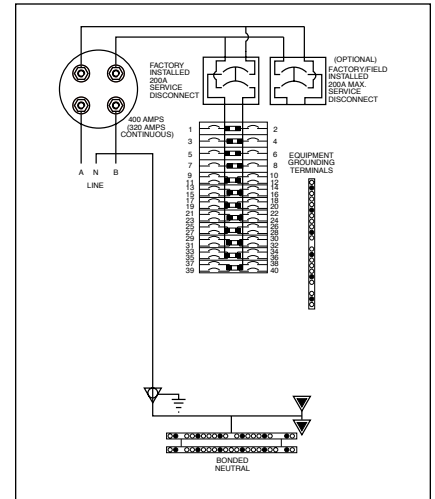

Figure 58. Type BR Wiring Diagram 6

Type BR Wiring Diagram Key

- #14-6 AWG
- #14-1/0 AWG
- ▽ #6 AWG - 250 kcmil
- ▽ #1 AWG - 300 kcmil

Typical Wiring Diagrams (Type BR Style House Panels)

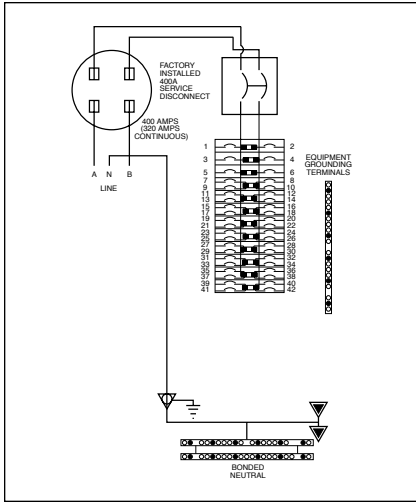

Figure 59. Type BR Wiring Diagram 7

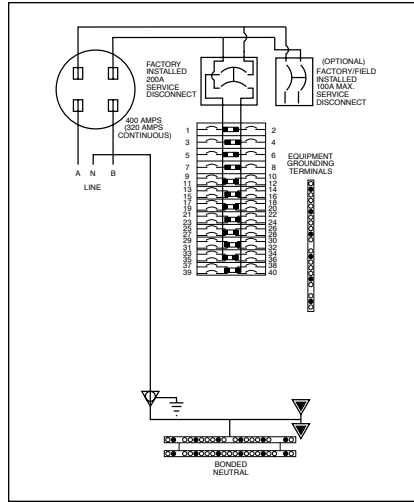

Figure 61. Type BR Wiring Diagram 9

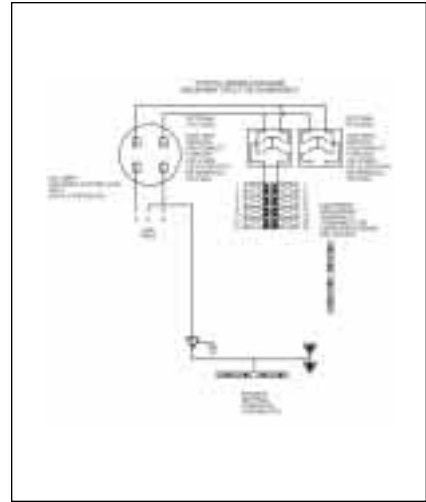

Figure 63. Type BR Wiring Diagram 11

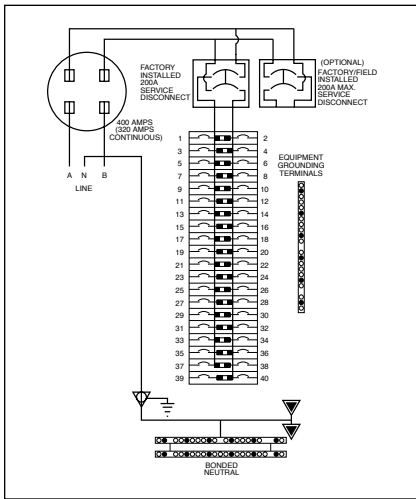

Figure 60. Type BR Wiring Diagram 8

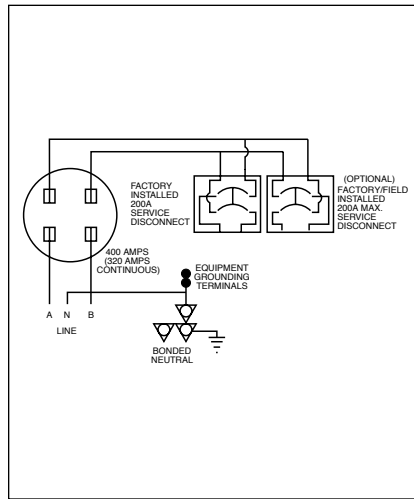

Figure 62. Type BR Wiring Diagram 10

Type BR Wiring Diagram Key

- #14-6 AWG
- #14-1/0 AWG
- ▽ #6 AWG - 250 kcmil
- ▽ #1 AWG - 300 kcmil

Dimensions and Knockouts (BR Style House Panels) — Dimensions in Inches

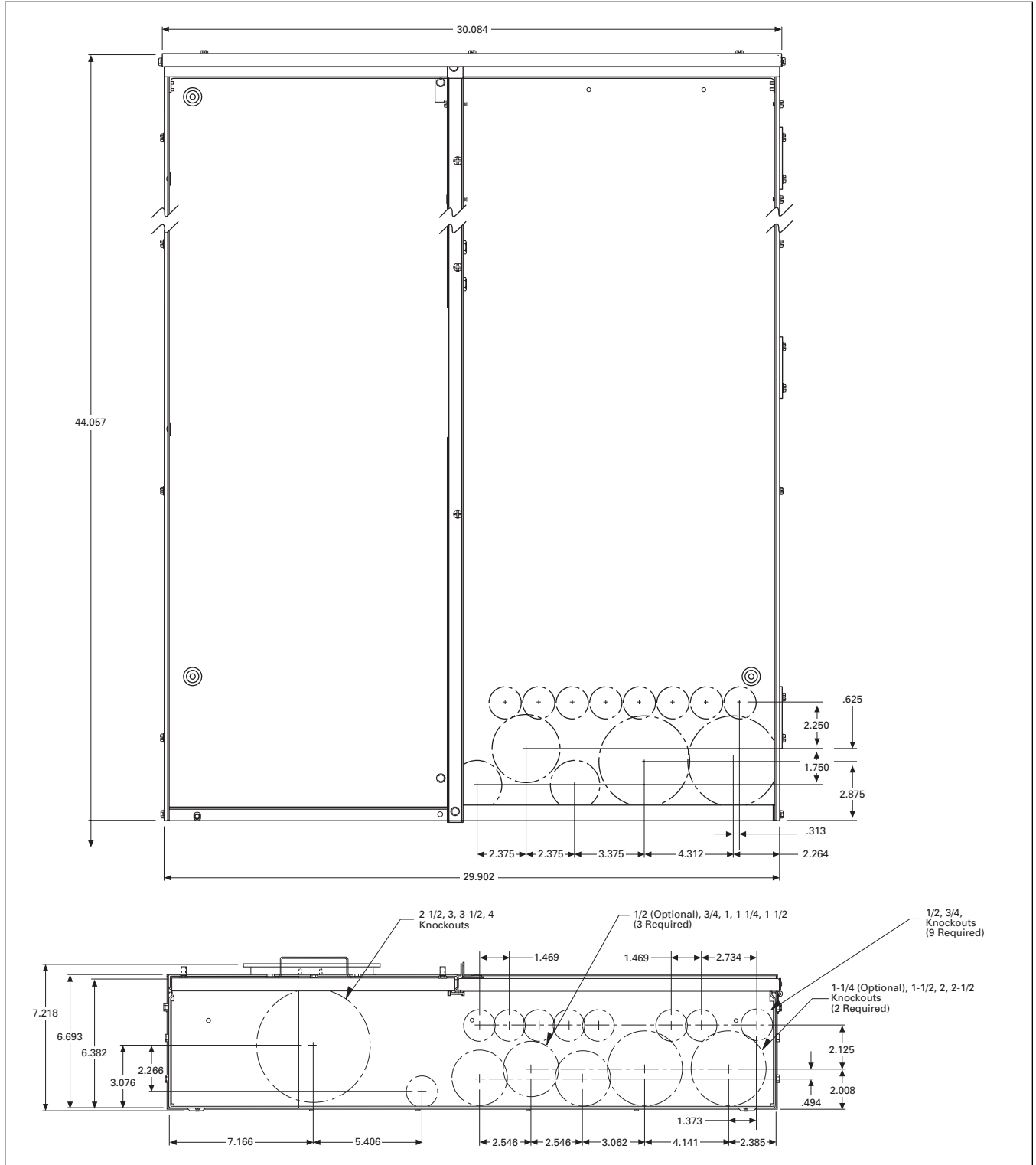

Figure 64. Type BR Meter Breaker Dimension Drawing 1

© 2001 Eaton Corporation,
All Rights Reserved

