

Superstrut

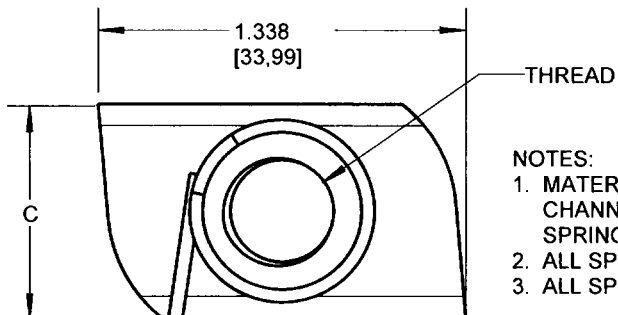
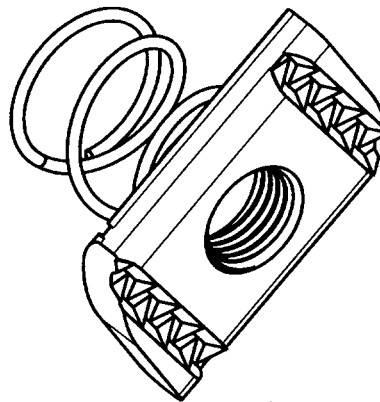
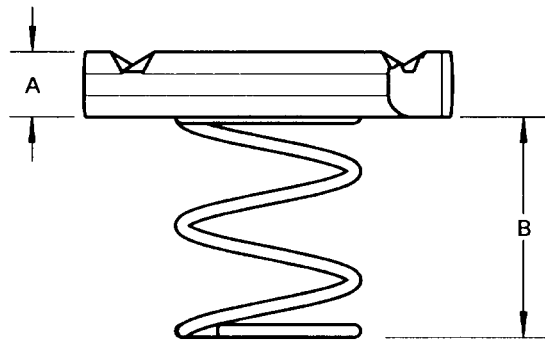

NOTES:

1. MATERIAL:
CHANNEL NUT: CARBON STEEL
SPRING: HARD DRAWN STEEL WIRE
2. ALL SPRINGS SHALL MECHANICALLY ATTACHED TO CHANNEL NUT
3. ALL SPRING NUTS SHALL BE ZINC PLATED

H100 1/2	1/2" UNIVERSAL SPRING NUT	.358 (9.1)	2.756 (70.0)	.785 (19.9)	1/2"-13 UNC	ELECTRO-GALV
H100 3/8	3/8" UNIVERSAL SPRING NUT	.358 (9.1)	2.756 (70.0)	.785 (19.9)	3/8"-16 UNC	ELECTRO-GALV
A100 7/8	7/8" UNIVERSAL SPRING NUT	.358 (9.1)	1.535 (39.0)	1.120 (28.5)	7/8"-9 UNC	ELECTRO-GALV
A100 3/4	3/4" UNIVERSAL SPRING NUT	.358 (9.1)	1.535 (39.0)	1.120 (28.5)	3/4"-10 UNC	ELECTRO-GALV
A100 5/8	5/8" UNIVERSAL SPRING NUT	.358 (9.1)	1.535 (39.0)	1.120 (28.5)	5/8"-11 UNC	ELECTRO-GALV
B100 5/16	5/16" UNIVERSAL SPRING NUT	.358 (9.1)	.394 (10.0)	.785 (19.9)	5/16"-16 UNC	ELECTRO-GALV
A100 5/16	5/16" UNIVERSAL SPRING NUT	.358 (9.1)	1.535 (39.0)	.785 (19.9)	5/16"-16 UNC	ELECTRO-GALV
B100 1/2	1/2" UNIVERSAL SPRING NUT	.358 (9.1)	.394 (10.0)	.785 (19.9)	1/2"-13 UNC	ELECTRO-GALV
A100 1/2	1/2" UNIVERSAL SPRING NUT	.358 (9.1)	1.535 (39.0)	.785 (19.9)	1/2"-13 UNC	ELECTRO-GALV
B100 3/8	3/8" UNIVERSAL SPRING NUT	.358 (9.1)	.394 (10.0)	.785 (19.9)	3/8"-16 UNC	ELECTRO-GALV
A100 3/8	3/8" UNIVERSAL SPRING NUT	.358 (9.1)	1.535 (39.0)	.785 (19.9)	3/8"-16 UNC	ELECTRO-GALV
B100 1/4	1/4" UNIVERSAL SPRING NUT	.238 (6.1)	.787 (20.0)	.785 (19.9)	1/4"-20 UNC	ELECTRO-GALV
A100 1/4	1/4" UNIVERSAL SPRING NUT	.238 (6.1)	1.535 (39.0)	.785 (19.9)	1/4"-20 UNC	ELECTRO-GALV
CAT #	DESCRIPTION	DIM "A"	DIM "B"	DIM "C"	THREAD	FINISH

GENERAL NOTES

1. ALL DIMENSIONS ARE FOR REFERENCE ONLY.
2. DIMENSIONS IN BRACKETS [] ARE IN METRIC UNITS.

www.tnb.com

Thomas & Betts
A Member of the ABB Group

DESCRIPTION:

UNIVERSAL SPRING NUT

REVISIONS

SEE ERN (2015003) FOR APPROVAL SIGNATURES & RELEASE DATE.
PROJECT NO:004V000518

ORIGINAL PROJECT NO / (ERN NO)

005D00094 / (2013203)

SHEET NO:

1 OF 1

REV. NO:

1

DRAWING NO:

WSD-001057

THIS DRAWING IS INTENDED FOR DESCRIPTIVE PURPOSES ONLY. AND THE RIGHT IS RESERVED TO DEVIATE FROM ANY OF THE DETAILS SHOWN HEREON.
COPYRIGHT THOMAS & BETTS CORPORATION. ALL RIGHTS RESERVED. PROPRIETARY AND CONFIDENTIAL

Superstrut

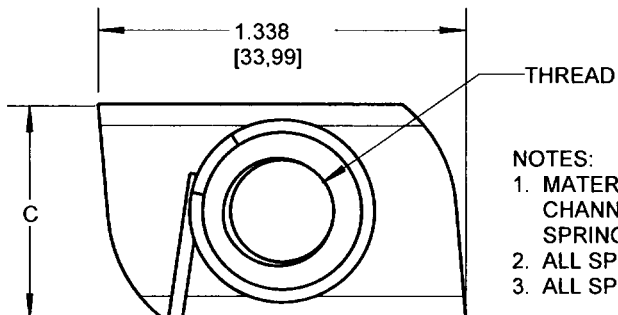
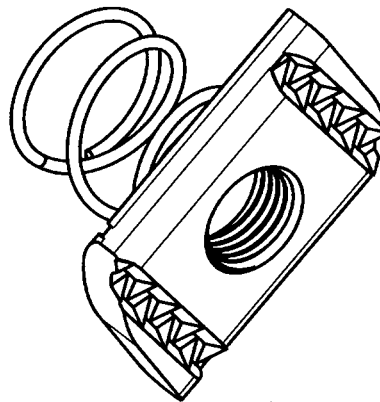
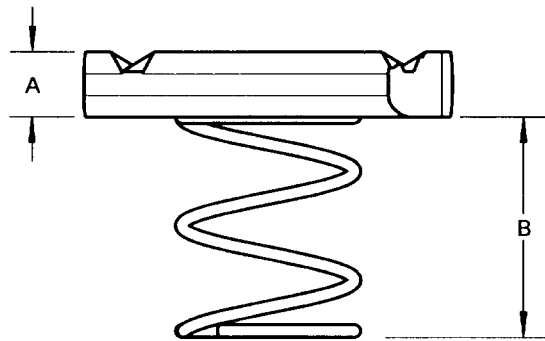

NOTES:

1. MATERIAL:
CHANNEL NUT: CARBON STEEL
SPRING: HARD DRAWN STEEL WIRE
2. ALL SPRINGS SHALL MECHANICALLY ATTACHED TO CHANNEL NUT
3. ALL SPRING NUTS SHALL BE ZINC PLATED

H100 1/2	1/2" UNIVERSAL SPRING NUT	.358 (9.1)	2.756 (70.0)	.785 (19.9)	1/2"-13 UNC	ELECTRO-GALV
H100 3/8	3/8" UNIVERSAL SPRING NUT	.358 (9.1)	2.756 (70.0)	.785 (19.9)	3/8"-16 UNC	ELECTRO-GALV
A100 7/8	7/8" UNIVERSAL SPRING NUT	.358 (9.1)	1.535 (39.0)	1.120 (28.5)	7/8"-9 UNC	ELECTRO-GALV
A100 3/4	3/4" UNIVERSAL SPRING NUT	.358 (9.1)	1.535 (39.0)	1.120 (28.5)	3/4"-10 UNC	ELECTRO-GALV
A100 5/8	5/8" UNIVERSAL SPRING NUT	.358 (9.1)	1.535 (39.0)	1.120 (28.5)	5/8"-11 UNC	ELECTRO-GALV
B100 5/16	5/16" UNIVERSAL SPRING NUT	.358 (9.1)	.394 (10.0)	.785 (19.9)	5/16"-16 UNC	ELECTRO-GALV
A100 5/16	5/16" UNIVERSAL SPRING NUT	.358 (9.1)	1.535 (39.0)	.785 (19.9)	5/16"-16 UNC	ELECTRO-GALV
B100 1/2	1/2" UNIVERSAL SPRING NUT	.358 (9.1)	.394 (10.0)	.785 (19.9)	1/2"-13 UNC	ELECTRO-GALV
A100 1/2	1/2" UNIVERSAL SPRING NUT	.358 (9.1)	1.535 (39.0)	.785 (19.9)	1/2"-13 UNC	ELECTRO-GALV
B100 3/8	3/8" UNIVERSAL SPRING NUT	.358 (9.1)	.394 (10.0)	.785 (19.9)	3/8"-16 UNC	ELECTRO-GALV
A100 3/8	3/8" UNIVERSAL SPRING NUT	.358 (9.1)	1.535 (39.0)	.785 (19.9)	3/8"-16 UNC	ELECTRO-GALV
B100 1/4	1/4" UNIVERSAL SPRING NUT	.238 (6.1)	.787 (20.0)	.785 (19.9)	1/4"-20 UNC	ELECTRO-GALV
A100 1/4	1/4" UNIVERSAL SPRING NUT	.238 (6.1)	1.535 (39.0)	.785 (19.9)	1/4"-20 UNC	ELECTRO-GALV
CAT #	DESCRIPTION	DIM "A"	DIM "B"	DIM "C"	THREAD	FINISH

GENERAL NOTES 1. ALL DIMENSIONS ARE FOR REFERENCE ONLY. 2. DIMENSIONS IN BRACKETS [] ARE IN METRIC UNITS.		 A Member of the ABB Group www.tnb.com				
REVISIONS - SEE ERN (2015003) FOR APPROVAL SIGNATURES & RELEASE DATE. PROJECT NO:004V000518						
		ORIGINAL PROJECT NO / (ERN NO) 005D00094 / (2013203)	SHEET NO: 1 OF 1	REV. NO: 1	DRAWING NO: WSD-001057	

THIS DRAWING IS INTENDED FOR DESCRIPTIVE PURPOSES ONLY, AND THE RIGHT IS RESERVED TO DEVIATE FROM ANY OF THE DETAILS SHOWN HEREON.
 COPYRIGHT THOMAS & BETTS CORPORATION. ALL RIGHTS RESERVED. PROPRIETARY AND CONFIDENTIAL.